

RotabroachTM

PNEUMATIC MAGNETIC DRILLING MACHINE



RAVEN

Model No. CM/330/C



Ex II 2GD c T6 IIC T85°C

This machine (Serial No _____) is CE approved.

Rotabroach Ltd
Burgess Road
Sheffield, South Yorkshire
United Kingdom
S9 3WD

Tel: +44 (0) 114 2212 510

Email: sales@rotabroach.co.uk Web site: www.rotabroach.co.uk

CONTENTS OF THE MANUAL

[1]	Specification	Page 4
[2]	Safety measures	Page 5
[3]	Operating instructions	Page 6
[4]	Mounting of cutters	Page 7
[5]	Remedies for hole making problems	Page 7
[6]	Maintenance	Page 9
[7]	Component parts of complete machine	Page 10
[8]	Atlas-Copco Motor	Page 12
[9]	Optional Extras	Page 13
[10]	Warranty	Page 15

	List of contents with drill unit	Check List
RD4329	Safety strap	YES/NO
RD4088	4mm A/F Tee handled hex key	YES/NO
RD4367	Pipe Adaptor Fixing Strap	YES/NO

Rotabroach™



EC DECLARATION OF CONFORMITY

ROTABROACH
IPERIAL WORKS
SHEFFIELD ROAD
TINSLEY
SHEFFIELD
S92YL

THE: MAGNETIC DIULLU-G MACHINE
MODEL CM/330/C
YEAR OF PRODUCTION 2006

MEETS THE RELEVANT ESSENTIAL HEALTH AND SAFETY REQUIREMENTS OF
EEC DIRECTIVE 94/9/EC

FOR USE IN POTENTIALLY EXPLOSIVE ATMOSPHERES

THE SAFETY AND HEALTH REQUIREMENTS OF EN 1127-1 AND EN13463
ARE COMPLIED WITH

CLASSIFICATION AND MARKING – II 2GD c T6 IIC T85°C

Responsible Person:

Name: James T. Chalmers
Signed: 
Position: Technical Manager.
Date: 28 April 2006

Technical File sent to Notified Body:
SIRA Test and Certification Ltd
South Hill
Chislehurst
Kent
BR75EH

Registered office: Rotabroach, Imperial Works, Sheffield Road, Tinsley, Sheffield, S9 2YL Tel +44 (0) 114 221 2510
Fax +44 (0)114 221 2563 Jim Chalmers direct dial +44 (0)114 221 2526
e-mail - james.chalmers@rotabroach.co.uk web site - www.rotabroach.co.uk
Registered Number 4333830 in England

[1] SPECIFICATION

ROTABROACH PNEUMATIC MAGNETIC DRILLING MACHINE

MODEL NO. CM/330/C - **MICRO-AIR**



II 2GD c T6 II C T85°C

Maximum hole cutting capacity in .2/.3C steel 52mm dia., 52mm deep.
Arbor bore 19.05mm dia. (3/4" dia.)

Motor Unit:	ATLAS COPCO LZB42 A0030	Speed 160 rpm
Magnet:	Manually operated Tractive force at 20°C (25mm minimum plate thickness) The use on any material less than 25mm thick will progressively reduce the magnetic performance. If possible substitute material should be positioned under the magnet and work piece to equate to a suitable material thickness. If this is not possible an alternative secure method of restraining the machine MUST be used. Failure to do so may result in personal injury.	700kgs
Overall dimensions:	Height (max. extended) Width (inc. capstan) Overall length (inc. guard and magnet handle)	540mm 185mm 370mm
Nett weight:		16.3kgs
Air supply required:	Pressure Minimum volume:	5.5 Bar (80 psi) min. 6.9 Bar (100 psi) max. 13 litres/sec 28 cu/ft/min
Sound pressure level (Ear protectors must be worn) Note: The figures quoted are emission levels and are not necessarily safe working levels. Whilst there is a correlation between the emission and exposure levels, this cannot be used reliably to determine whether or not further precautions are required. Factors that influence the actual level of exposure of the workforce include characteristics of the work room, the other sources of noise, etc. i.e. the number of machines and other adjacent processes. Also the permissible exposure level can vary from country to country. This information, however, will enable the user of the machine to make a better evaluation of the hazard and risk.		78 dB(A)

3/8" B.S.P. Male Connection Point

Note: This machine contains aluminium, and should not be used in any environment where the use of aluminium is prohibited, or may constitute a hazard, without the specific approval of an authorised person.

An in-line filter and lubricator must be used prior to the drilling unit and at a distance not greater than 5m. To achieve optimum service life and performance, lubrication should be applied at a rate of 50 cubic mm. of oil for each cubic metre of air consumed.

Depending upon the type of supply fittings used, it may be necessary to vent the supply to be able to disconnect the drill unit from the supply.

The motor should be purged with light lubricating oil after use.

NB: ANY MODIFICATIONS TO THIS MACHINE WILL INVALIDATE THE GUARANTEE

[2] SAFETY PROCEDURES

READ BEFORE USING THE MACHINE

Always secure the machine with the safety strap RD4329 before starting to operate - for the user's protection in case the magnetic base breaks loose whilst in use. Failure to do so may result in personal injury.

Always wear approved eye and ear protection when the equipment is in operation. .Failure to do so may result in personal injury.

Disconnect from pneumatic supply source when changing cutters or working on the machine. Ensure that the Air supply is connected after positioning the machine.

Never pick the machine up by the cutter as this is sharp and may injure you.

Always ensure cutter retaining screws are secure.

Regularly clear the work area and machine of swarf and dirt, paying particular attention to the underside of the magnet base.

With a gloved hand, and after switching off, remove any swarf, which might have gathered around the cutter and arbor before proceeding with the next hole.

Before operating the machine, remove tie, rings, watches and any loose adornments, which might entangle with the rotating machinery.

Ensure that the magnet is fully activated before attempting to cut a hole.

Should the cutter become 'fast' in the work piece, switch off the motor immediately to prevent personal injury. Disconnect from the pneumatic supply and turn arbor to and fro. **Do not attempt to free the cutter by switching the motor on and off.**

If the machine is accidentally dropped, always thoroughly examine the machine for signs of damage and check that it functions correctly before trying to drill a hole.

Regularly inspect the machine and check that all nuts and screws are tight.

Cutting tools may shatter **always** extended the guard over the cutter during the drilling operation. Failure to do so may result in personal injury. When moving the machine ensure the guard is over the cutter failure to do so may cause injury.

On completion of the cut, a slug will be ejected. DO NOT operate the machine if the ejected slug may cause injury.

Ensure an adequate supply of coolant is supplied to the cutter during the cutting cycle.

Manual handling

When moving the machine always ensure that you use the carry handle on the machine failure to do so may cause damage to the machine. Never pick the machine up by the cutter as this may cause injury.

Caution this machine is heavy and may require help maneuvering especially when working overhead.

[3] OPERATING INSTRUCTIONS

Before connecting the pneumatic supply ensure the motor switch is in the **OFF** position.

Locate the machine in the required position for cutting the hole and activate the magnet by means of the ratchet handle (clockwise viewed from rear). Ensure that magnet rod is fully screwed home.

Keep the inside of the cutter clear of swarf - it restricts the operating depth of the cutter.

Apply the cutting fluid to the reservoir via the inducement slots in the arbor. It is then «metered» out by the pilot and is applied directly to the cutting edge. (Alternatively, fluid can be applied directly on to the work piece making certain that it floods into the groove formed by the cutter.)

Depress the pilot to ensure cutting fluid is being correctly metered.

Start the motor by turning the rotary valve to **ON** position see below



Apply light pressure when commencing to cut a hole until the cutter is introduced into the work surface. Pressure can then be increased sufficiently to load the motor. Excessive pressure is undesirable when using the *Rotabroach Micro-Air* machine, it does not increase the speed of penetration and may cause the motor to stall. The motor will restart when the excessive pressure is released.

Always ensure that the slug has been ejected from the previous hole before commencing to cut the next.

If the slug sticks in the cutter, move the machine to a flat surface, switch on the magnet and gently bring the cutter down to make contact with the surface. This will usually straighten a cocked slug and allow it to eject normally.

Apply a small amount of light oil lubricant regularly to slide and arbor support bearing. Cutter breakage is usually caused by insecure anchorage, a loosely fitting slide or a worn bearing in the arbor support.

[4] MOUNTING OF CUTTERS

The following procedure is to be used when mounting cutters.

ALWAYS DISCONNECT MACHINE FROM PNEUMATIC SUPPLY

Lay the machine on its side with feed handles uppermost, ensuring arbor is wound down to its lowest point to enable access to socket screws RD4066. Take the appropriate pilot and place through hole in shank of cutter. Insert shank of cutter into arbor ensuring alignment of two drive flats with socket screws RD4066. Tighten both screws securely using hexagon key RD4088.

[5] REMEDIES FOR HOLE MAKING PROBLEMS

Problem	Cause	Remedy
Magnetic base won't hold effectively	Material being cut may be too thin for efficient holding	Attach an additional piece of metal under work piece where magnet will be located, or mechanically clamp magnetic base to work piece
	Swarf or dirt under magnet	Clean magnet
	Irregularity on contact between magnet and work piece	Use extreme care, file only imperfections flush on to surface
Hole not cut at intended centre of cut	Magnetic base is not holding effectively	See causes and remedies above
	Worn arbor bushing and/or ejector collar	Replace! Only a few thousandths wear permissible. New arbor bushing is needed
	Too much feed pressure at start of cut	Light pressure until a groove is cut. The groove then serves as a stabilizer
	Cutter is dull, worn, chipped or incorrectly sharpened	Replace or re-sharpen. Sharpening service is available
	Worn or bent pilot, worn pilot hole	Replace part or parts
Loose bolts on motor bushing support bracket, main casting or loose gib adjusting set screws	Adjust where necessary	

Poor hole quality, cutter not cutting, motor stops	Incorrectly re-sharpened, worn or chipped cutter	Re-sharpen or replace
	Coming down on swarf lying on surface of work piece	Take care not to start a cut on swarf
	Insufficient air pressure/volume	Check air supply
	Gibs out of adjustment or lack of lubrication	Adjust set screws
	Swarf accumulated (packed) inside cutter	Clear cutter

Problem	Cause	Remedy
Excessive cutter breakage	Steel swarf or dirt under cutter	Remove cutter, clean part thoroughly and replace
	Incorrectly re-sharpened or worn cutter	Always have a new cutter on hand to refer to for correct tooth geometry, along with instruction sheet
	Cutter skipping	See cause and remedy above
	Slideway needs adjustment	Adjust gibs
	Cutter not attached tightly to arbor	Retighten
	Insufficient use of cutting oil or unsuitable type of oil	Inject oil of light viscosity into the slot in the arbor and check to be sure oil is being metered into cutter when pilot is depressed. If not, check pilot groove and arbor internally for dirt or apply oil externally. Even a small amount of oil is very effective
Excessive cutter wear	See cause and remedy above	
	Incorrectly re-sharpened cutter	Refer to instructions and a new cutter for proper tooth geometry
	Insufficient or spasmodic cutting pressure	Use sufficient steady pressure to slow the drill down. This will result in optimum cutting speed and chip load
Motor will not start	Insufficient air pressure/volume	Check air supply, spindle free to rotate

[7] MAINTENANCE

To be conducted only by authorised personnel

In order to ensure that the unit is used to its full efficiency there are a few basic maintenance needs to observe. A regular check out of the machine will also ensure a prolonged «life» for the cutters and easier operation.

Before proceeding with any maintenance work be certain that the pneumatic supply is disconnected

ADJUSTMENT OF SLIDE AND ARBOR SUPPORT BRACKET

An essential requirement of the machine is that the slide which controls the movement of the cutter, can move in a smooth and controlled manner, free of lateral movement and vibration.

This situation can be maintained by periodic adjustment of the slide and is accomplished in the following manner:

- Place the machine in a vertical position and, by means of the capstan, raise the slide to its highest position, thus exposing the maximum possible amount of the vee slideway. Clean the slideways thoroughly and apply a small amount of light machine oil to the wear surfaces.
- Now drop the slide to its lowest position within the main housing and loosen screws, thus allowing free movement of the arbor support bracket.
- With the hexagonal key located and commencing with the two inner screws, gently feed in all the screws until slight resistance is encountered.
- Operate the slide up and down a few times to test the movement and make any further necessary adjustments. Try to ensure that all the screws are exerting a uniform pressure on the slide from top to bottom.
- A perfectly adjusted slide will operate freely up and down without any sideways movement.
- Now, using fingers only, tighten the screws holding the arbor support bracket.
- Place the machine on a steel plate, connect to supply and activate the magnet. Start up the motor. If the arbor is incorrectly aligned, the arbor support bracket will be seen to oscillate. Make any necessary further adjustments to the bracket to ensure correct alignment of the spindle and finally tighten the screws using a hex key.

[8] PARTS LIST – CM/330/C

Item	Component	Part No.	Item	Component	Part No.
1	Motor packing	RD33117	42	M6 spring washer	RD4207
2	Magnet	RD43100	43	M6 socket head cap screw	RD4098
4	Motor	RD43105	44	Capstan arm	RD33089
6	Housing	RD33124	45	Plastic knob	RD43091
8	Slide	RD33125	46	M6 socket screw	RD4312
9	Motor Bracket	RD3357	47	Tension pin	RD4102
10	Rack	RD33097	48	Name plate	RD33140
11	Fixed gib strip	RD33103	49	Information plate	RD4362
12	Adjustable gib strip	RD33104	54	Ball	RD45620
13	Gib support strip	RD33105	53	Face plate	RD33116
14	Spirol pin	RA353	55	Guard	RD33345
15	Bearing bracket spacer.	RD3324	56	Guard Slide	18Y3000
16	Thrust washer	RD4519	60	Guard support	RD33344
17	Bearing	RD4518	62	3/8" BSP elbow	RD43020
18	Arbor sleeve	RD33100	63	3/8" BSP ball valve	RD43021
19	Bearing bracket	RD33122	64	Silencer	RD4355
20	External circlip	RD43084	65	Hex adaptor	RD4389
21	Key	RD3355	66	Ratchet handle *	RD43104
22	M5 shakeproof washer	RD4092	67	M6 socket head cap screw	RD4156
23	M6 shakeproof washer	RD4096	68	M6 washer	RD33030
24	M6 socket head cap screw	RD4394	71	Button	RA354
25	M5 socket head cap screw	RD4325	72	Spring	RA355
26	M6 stud	RD4340	73	Arbor	RD3384
27	M4 shakeproof washer	RD4069	74	Circlip	RD4056
28	M4 pan head screw	RD4077	75	M8 socket screws	RD4066
29	M8 washer	RD4078	77	M5 countersunk screw	RD4347
30	M8 shakeproof washer	RD4079	78	M8 socket screws dog point	RD43135
31	M6 nut	RD4087	79	M12 grub screw	RD4081
32	M6 washer	RD4095	80	PG16 plastic insert	RD43138
35	M8 bolt	RD4319	81	Washer	RD43136
39	Capstan pinion shaft	RD33088	82	Pole piece set	RD43047
40	Pinion shaft sleeve	RD33090	83	Magnet Washer	RD33030
41	Bearing	RD33092			

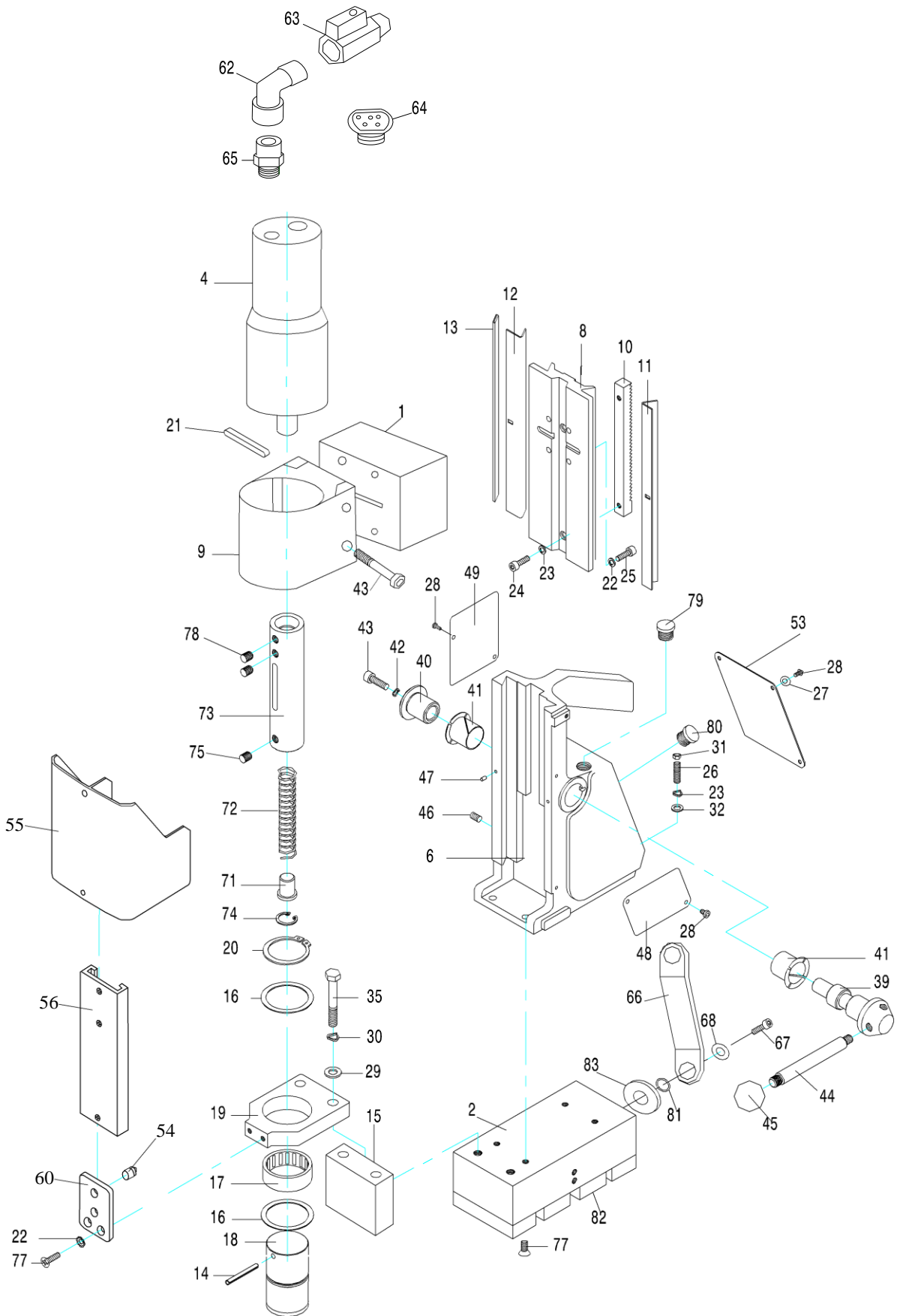

[9] ATLAS-COPCO MOTOR

Three-stage gear unit - for A0030

Ref No.	Part No	Qty	Description
39 (40-42)	4430 0563 80	1	Gear rim complete
40	-	1	Gear rim (z = 47)
41	4090 0704 00	1	Lubricating nipple
42	0335 3508 01	1	Circlip (SB45)
43	4430 0559 00	1	Front part
44	0666 8003 05	1	Seal ring (G30 x 37 x 4)
45	0337 2622 00	1	Key (R6 x 6 x 30)
46	0502 3304 00	1	Ball bearing (6304-Z)
47	4430 0562 00	1	Nut
48 (49-50)	4430 0492 80	1	Gear rim complete
49	-	1	Gear rim (z = 45)
50	4090 0588 00	1	Circlip (BR35)
67	4430 0554 00	1	Washer
68	4170 0505 00	1	Cup spring
69	0663 9026 00	1	O Ring (40 x 1.78)
113(114-120)	4430 0547 80	1	Planetary gear complete (i = 4.62)
114	-	1	Planet shaft (Ø19mm)
117	4210 2214 00	1	Gear wheel (z = 15)
118	0517 0100 05	48	Bearing needle (1.5 x 13.8)
119	4210 2213 00	6	Washer (6.3/9.1 x 0.5)
120	4210 2215 00	3	Axle pin (6.22h6 x 23.5)
121	0502 1504 00	1	Ball bearing (16004)
122	4210 2220 00	1	Bushing
123 (124-127)	4430 0549 80	1	Planetary gear complete (i = 4.46)
124	-	1	Planet shaft (z = 13)
125	4430 0467 00	3	Gear wheel (z = 15)
126	0515 1103 01	3	Needle bearing (K5 x 8 x 10 TN)
127	0517 0100 11	3	Bearing roller (NRB 5.0 x 19.8)
128	0502 1103 00	1	Ball bearing (6003)
129	4430 0557 00	1	Washer
96 (97-98)	4430 0484 80	1	Planet shaft complete (i = 3.25)
97	-	1	Planet shaft (z = 13)
98	0517 0100 13	3	Bearing roller (NRB 3.0 x 17.8)
106	0515 0100 13	3	Needle bearing (K3 x 5 x 9 TN)
107	4430 0475 00	3	Gear wheel (z = 12)
111	4430 0556 00	1	Washer
112	4430 0474 00	1	Gear wheel (z = 11/20)

[10] OPTIONAL EXTRAS

ROTABROACH CUTTING FLUID

Specially formulated for maximum cutter life.
Available in three sizes:

1 litre RD208

5 litre RD229

Chuck adaptor.

RD33025

Enables the existing arbor to be replaced to utilize twist drill chucks.

To fit adaptor, remove socket set screws RD4368 (item No 78) and arbour RD3384 (item No 73).

Insert adaptor RD33025 onto end of motor spindle and lock into position.

Chuck Kit.

RD440 5/8" capacity chuck + key

RD324 Chuck spacer

To fit chuck, replace existing chuck adaptor (as described above) and screw chuck onto adaptor.

NOTES:



WARRANTY STATEMENT

Rotabroach® warrants its machines to be free from faulty materials, or workmanship under normal use for a period of 12 months from initial date of purchase and 90 days for all other parts (excluding cutters), provided that the warranty registration card (or online registration) has been completed and returned to Rotabroach®, or its designated distributor within a period of (30) days from the purchase date, failure to do so will void the warranty. If the stated is adhered to Rotabroach® will repair or replace (at its option) without charge any faulty items returned.

This Warranty does not cover:

1. Components that are subject to natural wear and tear caused by the use in accordance with the operators instructions
2. Defects in the tool caused by non-compliance with the operating instructions, improper use, abnormal environment conditions, inappropriate operating conditions overload or insufficient servicing or maintenance.
3. Defects caused by using accessories, components or spare parts other than original Rotabroach® parts.
4. Tools to which changes or additions have been made.
5. Electrical components are subject to manufacturer's warranty.

Your online registration can be submitted on www.rotabroach.co.uk

The warranty claim must be lodged within the warranty period. This requires the submission or sending of the **complete** tool in question with the original sales receipt which must indicate the purchase date of the product. A complaint form must also be submitted prior to the return.

This can be found online at www.rotabroach.co.uk Failure to complete this form will result in the delay of your claim.

All goods returned defective must be returned pre-paid to Rotabroach®, in no event shall Rotabroach® be liable for subsequent direct, or indirect loss or damage.

THIS WARRANTY IS IN LIEU OF ANY OTHER WARRANTY, (EXPRESSED OR IMPLIED) INCLUDING ANY WARRANTY OF MECHANICALITY OR FITNESS FOR A PARTICULAR PURPOSE. ROTABROACH® RESERVE THE RIGHT TO MAKE IMPROVEMENTS AND MODIFICATIONS TO DESIGN WITHOUT PRIOR NOTICE