

# ***Rotabroach***<sup>TM</sup>

## **RHINO 2 PETROL DRIVEN RAIL DRILLING MACHINE**



**Model No. RD07A**  
(STIHL BT131)

**RAILTRACK CERTIFICATE NUMBER: NT/PT/0024/99**

This machine (Serial No \_\_\_\_\_) is CE approved.

**Rotabroach Ltd**  
Burgess Road  
Sheffield, South Yorkshire  
United Kingdom  
S9 3WD

Tel: +44 (0) 114 2212 510      Fax: +44 (0) 114 2212 563  
Email: [sales@rotabroach.co.uk](mailto:sales@rotabroach.co.uk)      Web site: [www.rotabroach.co.uk](http://www.rotabroach.co.uk)

**Thank you for purchasing our Rhino RD07 petrol rail drill.  
We would really like your feedback on this machine.**

***Other Products by Rotabroach:***



**Thank you for your purchase**

## CONTENTS OF THE MANUAL

		Page No
[1]	Specification of machine	4
[2]	Safety procedures	5
[3]	Cutting fluid	5
[4]	Coolant inducement	5
[5]	Fuelling and mixture	6-7
[6]	Motor operating instructions	8-10
[7]	Machine operating instructions	11
[8]	Cutters for rail drilling machines	12
[9]	Maintenance - general	13-14
[10]	Maintenance - motor	15-19
[11]	Exploded view of arbor/spindle assembly	20-21
[12]	Exploded view of arbor/spindle drive	22-23
[13]	Exploded view of arbor/spindle feed	24-25
[14]	Parts list for rail clamp	26-29
[15]	Warranty	30

<b>List of contents with drill unit</b>		<b>Check list</b>
RD439	3/16" Allen Key	YES/NO
RD4088	4mm A/F Tee handled hex key	YES/NO
RD40038	8mm Hex key	YES/NO
RY2307	Coolant Feed Dispenser	YES/NO

**[1] ROTABROACH RAIL DRILLING MACHINE MODEL RD07A**

Maximum hole cutting capacity 36mm dia.

Arbor bore 19.05mm dia. (3/4")

Engine	Engine Speed	
STIHL Model BT131 36.3cm <sup>3</sup> displacement On load torque 74.4Nm @ 150rpm Fuel tank capacity 0.8 litres	No load (engine)	9560rpm
	No load (arbor/spindle)	200rpm
	Normal full load (arbor/spindle)	150rpm
Petrol/oil mix	50:1 with Stihl 25:1 other brands	
Overall dimensions	Length	500mm
	Width	420mm
	Height	450mm
Net Weight	19.2kgs	
Maximum hand/arm vibration magnitude (measured at handle during operation in accordance with ISO5349)	15.6 m/s <sup>2</sup>	
Estimate of likely daily vibration exposure – Operation on 2 Rails (24 holes @ 1 minute/hole)	2.47 m/s <sup>2</sup> A(8)	
Average noise level during cutting at operators ear position.	92dB(A)	

**EAR DEFENDERS MUST BE WORN WHEN THE MOTOR IS RUNNING.**

***ANY MODIFICATIONS TO THIS MACHINE WILL INVALIDATE THE GUARANTEE***

## [2] SAFETY PROCEDURES

### ***READ BEFORE USING THE MACHINE***

- **ALWAYS WEAR SAFETY GOGGLES AND EAR DEFENDERS WHEN OPERATING THE MACHINE.**
- Ensure motor is switched off when changing cutters, working on the machine, or clearing swarf.
- Always ensure cutter-retaining screws are secure.
- Regularly clear the work area and machine of swarf and dirt.
- Read section [5] page 5 before attempting to fuel the machine.
- Remove tie, rings, watches and loose adornments, which might entangle with the rotating machinery.
- Should the cutter become *fast* in the work piece, switch off the motor immediately to prevent personal injury and turn the arbor to and fro. ***Do not attempt to free the cutter by starting and stopping the motor.***
- If the machine is accidentally dropped, always thoroughly examine the machine for signs of damage and check that it functions correctly before trying to drill a hole.
- Regularly inspect the machine and check that nuts and screws are tight.

## [3] ROTABROACH CUTTING FLUID

- Rotabroach cutting fluid has been specifically formulated to significantly enhance the performance and life of the cutting tool, and improve the quality and surface finish of the hole.
- Rotabroach cutting fluid is available in 1 litre (RD208) and 5 litre (RD229) bottles.

## [4] COOLANT INDUCEMENT

- Constituent items:  
Coolant bottle and hose assembly RY2307

**[5] FUELLING**

The Rotabroach drilling machine uses an oil-petrol mixture for fuel.

***Warning***

**Petrol is an extremely flammable fuel.  
Use extreme caution when handling petrol or fuel mix.  
Do not smoke or bring any fire or flame near the fuel.  
Ensure the fuel mix does not spill on to hot engine.**

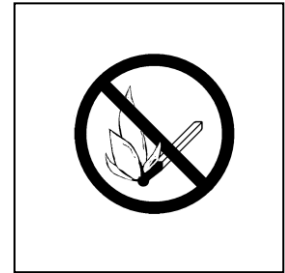
**FUELLING INSTRUCTIONS**

- Fuel your machine in a well-ventilated area, outdoors only.
- Always shut off the engine and allow it to cool before refuelling.
- Petrol vapour pressure may build up inside the gas tank of a two-cycle engine depending on the fuel used, the weather conditions and the venting system of the tank. In order to reduce the risk of burns or other personal injury from escaping gas vapour and fumes, remove the gas cap on the STIHL product carefully so as to allow any pressure build-up in the tank to release slowly. Never remove the fuel filler cap whilst the engine is running,

**FUEL MIX**

- Prepare the mixture of brand name petrol and quality two-stroke engine oil in an approved safety type canister. Pour in the oil first and then add the petrol.
- STIHL two-stroke engine oil is recommended. It is formulated specially for STIHL engines and guarantees a long engine life.
- It is recommended that you always use unleaded petrol with a minimum octane number of 90 ROZ(USA)/Canada: pump octane min. 87.
- Inferior quality petrol or oils may damage the engine, sealing rings, fuel lines or fuel tank.

**MIX RATIO**

- With STIHL 50:1 two-stroke engine oil: 50 parts petrol to 1 part oil.
- With other branded two-stroke air cooled engine oils: 25 parts petrol to 1 part oil.

For example:

<b>Petrol</b>	<b>STIHL Oil 50:1</b>		<b>Other branded 2-stroke oils 25:1</b>	
Litres	Litres	(cc)	Litres	(cc)
1	0.02	(20)	0.04	(40)
5	0.10	(100)	0.20	(200)
10	0.20	(200)	0.40	(400)
15	0.30	(300)	0.60	(600)
20	0.40	(400)	0.80	(800)
25	0.50	(500)	1.00	(1000)
<b>US gal.</b>	<b>US fl.oz.</b>		<b>US fl. oz.</b>	
1	2½		5 <sup>1</sup> / <sub>8</sub>	
2½	6½		12 <sup>3</sup> / <sub>4</sub>	
5	12¾		25¾	

## FUEL MIXAGES

- Only mix sufficient fuel for a few months work - store in approved safety type canisters.
- Thoroughly shake the mixture in the canister before fuelling your machine.
- **Caution: Pressure may build up in the canister!** Open it slowly.
- Clean the fuel tank and canister from time to time.
- Take care when handling petrol. Avoid direct contact with the skin and avoid inhaling fuel vapour.
- **Change the fuel pickup body every year.**
- **Before fuelling, clean the filler cap and the area round it to ensure that no dirt falls into the tank.**

## [6] MOTOR OPERATING INSTRUCTIONS

### STARTING

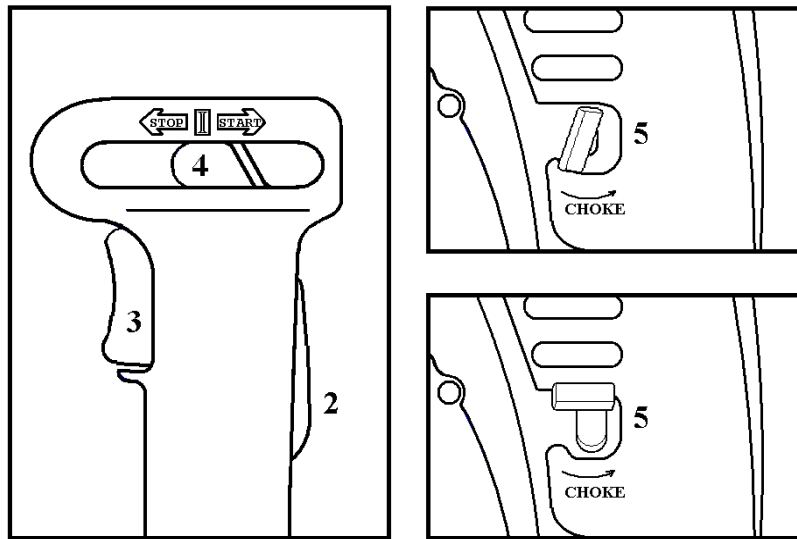

Observe safety precautions - see section «**Safety Procedures**»

- Press throttle trigger interlock (2) and squeeze throttle trigger (3). Move slide control (4) to START and then release throttle trigger, slide control and throttle trigger interlock in that order.
- **For cold start:** turn choke knob (5) to CHOKE.
- **For warm start:** (even if engine has been running but is still cold) - turn choke knob (5) away from CHOKE.

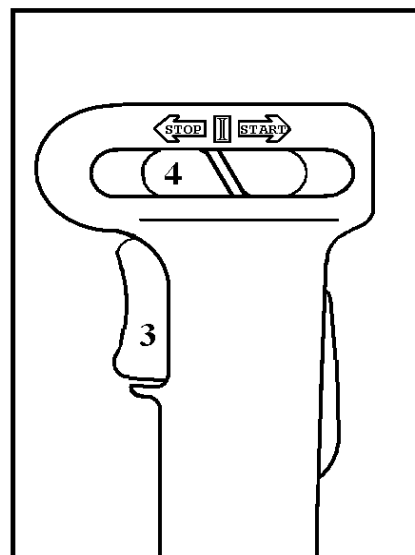
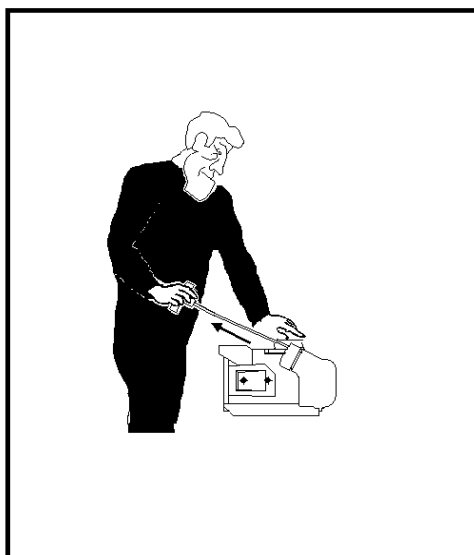



- Ensure machine is clamped firmly in position on rail. Pull the starter grip slowly with your right hand until you feel it engage - then give the grip a brisk, strong pull - do not pull out starter rope more than 60cm (about 2ft) - it might otherwise break.
- Do not let the starter grip snap back - guide it slowly into the housing so that the starter rope can rewind properly.
- If the engine is new, pull starter grip several times to prime the fuel line.
- When the engine begins to fire, move the choke knob away from CHOKE and continue cranking - **as soon as the engine runs, IMMEDIATELY blip the throttle trigger (3)** - the slide control (4) springs back to RUN position (I) and the engine settles down to idling speed.
- The arbor should not rotate whilst the engine is idling. If it does, check carburettor setting.
- Your machine is now ready for operation.
- To shut down engine - move slide control to STOP.

**At very low outside temperatures allow the engine to warm up.**

**If the engine doesn't start:**

- The combustion chamber may have flooded if you didn't move the choke knob away from CHOKE quickly enough after the engine began to fire.
- Pull off the spark plug terminal. Unscrew and dry off the spark plug. Set the slide control to STOP. Squeeze the throttle trigger fully. Crank the engine several times with the starter to clear the combustion chamber. Refit the spark plug and connect the spark plug terminal. Move the slide control to START position and choke knob away from CHOKE - even if the engine is cold. Now start the engine.

**Fuel tank run until dry and then refuelled:**

- Pull the starter rope several times until the fuel line is primed.

**During break-in period:**

- A factory new machine should not be run at high revs (full throttle off load) for the first three tank fillings. This avoids the unnecessarily high loads during the break-in period.
- As all moving parts have to bed in during the break-in period, the frictional resistances in the engine are greater during this period. The engine develops its maximum power after about 5 to 15 tank fillings.

**During operation:**

- After a long period of full throttle operation, allow the engine to run for a short while at idling speed so that the engine heat can be dissipated by the flow of cooling air. This protects engine mounted components (ignition, carburettor) from thermal overload.
- Check spark plug electrode gap about every 50 operating hours - it should be 0.5mm (0.020ins) - and adjust if necessary.

**After finishing work:**

- *Storing the machine for a short period:* Fill the fuel tank and keep the machine in a dry place until you need it again.
- *Storing the machine for a long period:* Drain and clean the fuel tank. Run the engine until the carburettor is dry.
- Check tightness of nuts and screws (except adjusting screws) at regular intervals and retighten if necessary.

## [7] MACHINE OPERATING INSTRUCTIONS

- Keep the inside of the cutter clear of swarf. It restricts the operating depth of the cutter.
- Pressurise the coolant dispenser by pumping the handle until the relief valve extends and then give a further 5 to 10 pumps of the handle.
- With the pressurised cutting fluid dispenser connected to the coolant feed tube, coolant is “metered” out by the pilot and is applied directly to the cutting edge.
- To ensure cutting fluid is being correctly metered, depress the pilot by slowly moving the cutter to touch the rail. Regulate the flow by adjusting the needle valve RD4217.
- Move the cutter 3-4mm away from the rail and run the engine to full throttle by pressing throttle trigger (3) and interlock (2) together (see page 7) to achieve maximum RPM. Once drilling is complete immediately release the throttle trigger (3), this will return the machine to idle speed. **DO NOT ALLOW THE MACHINE TO RUN AT FULL SPEED IF NOT DRILLING.**
- When commencing to cut a hole apply light pressure until the cutter is introduced into the work surface. Pressure can then be increased slightly whilst cutting the hole. **Excessive pressure** is undesirable when using the Rotabroach system, it does not necessarily increase the speed of penetration, it may damage the cutter greatly reducing its life.
- Cutter breakage is usually caused by insecure clamping.

### CAPSTAN AND THROTTLE CONTROL

The Rotabroach RD07 machine is provided with a versatile capstan and throttle control. Both can be adjusted to suit your personal preference.

#### ROTATING THROTTLE CONTROL.

- Remove the Stihl screw (Item 13, see diagram on page 24) from the capstan handle using the Stihl spanner provided.
- Rotate the throttle handle through 180°.
- Replace the Stihl screw.

#### ADJUSTING ANGULAR POSITION OF CAPSTAN HANDLE.

(See diagram on page 24)

- Remove the capstan spindle (Item 8) from the main housing.
- Remove the capstan spindle housings (Item 3).
- Reposition the feed gear (Item 6) and the capstan spindle to give the desired orientation of the capstan.
- Replace the capstan spindle housings.

**[8] ROTABROACH CUTTERS FOR RAIL DRILLING MACHINES**

All cutters have a 3/4" dia. shank.

**ALWAYS ENSURE THAT THE MACHINE IS SWITCHED OFF**

Take the chosen cutter and insert into its shank the appropriate pilot. Place the assembly, correctly aligning the drive flats, into the arbor bore and securely fasten the socket screws with the hexagon key.

<i>Dia. mm</i>	<b>SRCV SERIES (High wear)</b>		<b>SCRWC SERIES (Carbide Tipped)</b>	
	<i>Part No</i>	<i>Pilot No</i>	<i>Part No</i>	<i>Pilot No</i>
18	SRCV180	SRA25	SCRWC18	SRA25
19	SRCV190	SRA25	SCRWC19	SRA25
20	SRCV200	SRA25	SCRWC20	SRA25
21	SRCV210	SRA25	SCRWC21	SRA25
22	SRCV220	SRA25	SCRWC22	SRA25
23	SRCV230	SRA25	SCRWC23	SRA25
24	SRCV240	SRA25	SCRWC24	SRA25
25	SRCV250	SRA25	SCRWC25	SRA25
26	SRCV260	SRA25	SCRWC26	SRA25
27	SRCV270	SRA25	SCRWC27	SRA25
28	SRCV280	SRA25	SCRWC28	SRA25
29	SRCV290	SRA25	SCRWC29	SRA25
30	SRCV300	SRA25	SCRWC30	SRA25
31	SRCV310	SRA25	SCRWC31	SRA25
32	SRCV320	SRA25	SCRWC32	SRA25
33	SRCV330	SRA25	SCRWC33	SRA25
34	SRCV340	SRA25	SCRWC34	SRA25
35	SRCV350	SRA25	SCRWC35	SRA25
36	SRCV360	SRA25	SCRWC36	SRA25

**WHEN ORDERING CUTTERS AND PILOTS ALWAYS QUOTE SERIES TYPE AND PART NUMBER**

**[9] MAINTENANCE (General)****TO BE CONDUCTED ONLY BY AUTHORISED PERSONNEL**

In order to ensure that the unit is used to its full efficiency there are a few basic maintenance needs to observe. A regular check-out of the machine will also ensure a prolonged life for the cutters and easier operation.

***Before proceeding with any maintenance work, be certain that the motor control switch is in the OFF position.***

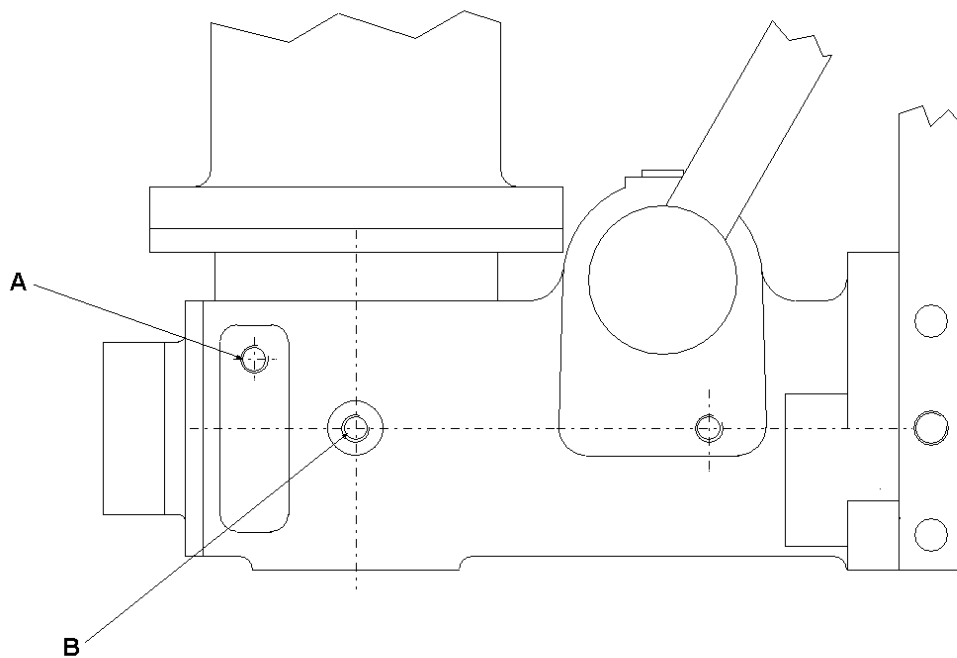

To check the gearbox oil level. Remove plugs A and B and check that the oil level is up to the level of the bottom of the threaded hole B. If not fill with Renogear V220EP through hole A until it flows from hole B. Replace plugs A and B.

**Maximum gearbox fill level is 90 millilitres.**

		Before starting work	After finishing work or daily	After each refuelling stop	Weekly	Monthly	If faulty	If damaged	As required	See page
Complete machine	Visual inspection (condition, leaks)	X		X						
	Clean		X							
Throttle trigger, stop switch	Check operation	X		X						7
Filter in fuel tank	Clean wire mesh filter					X				
	Replace foam element						X			
Fuel tank	Clean					X				
Air filter	Clean								X	17
	Replace							X		17
Cooling inlets	Clean								X	
Cylinder fins	Clean					X				
Carburettor	Check idle adjustment (drilling spindle must not turn)	X								16
	Readjust idle								X	16
Spark plug	Readjust electrode gap						X			17
All accessible screws and nuts (not adjusting screws)	Retighten								X	
Drilling gear	Relubricate								X	
Drilling spindle	Clean		X							

**[10] MAINTENANCE (Motor)****TO BE CONDUCTED ONLY BY AUTHORISED PERSONNEL****ADJUSTING CARBURETTOR**

The carburettor is set on the production line to obtain optimum performance at the barometric pressure and climatic conditions at the factory.

- Check the air filter - clean it if necessary
- Warm up the engine.
- Use a tachometer - do not exceed maximum permissible engine RPM - the engine could be damaged by insufficient lubrication and overheating. Maximum engine speed is 12,000 rpm.

If you have to readjust the carburettor from scratch, first carry out the basic setting as described below:

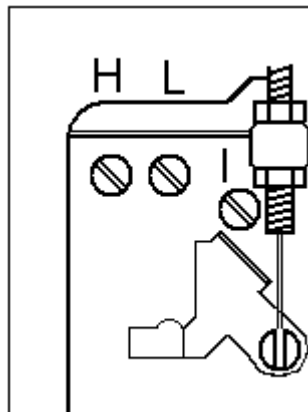
**Basic setting**

- Back off high speed adjusting screw (H) one full turn.
- Back off low speed adjusting screw(L) one full turn.
- If you don't have a tachometer, do not set the high speed adjusting screw any leaner by turning it beyond this basic setting.

Minor corrections may be necessary when operating at high altitude (mountains) or sea level

- Turn high speed adjusting screw (H) and low speed adjusting screw (L) clockwise (leaner) for operation at high altitude or counter-clockwise (richer) for operation at sea level.

- Turn screws very carefully - even very slight changes have a noticeable effect on engine running behaviour.

#### **Corrections to high speed adjusting screw:**

- Maximum off-load engine speed is altered with high speed adjusting screw (H). The engine's maximum permissible rpm will be exceeded if the setting is too lean - this could damage the engine.
- Do not set the carburettor leaner to obtain an apparent increase in power - you might exceed the engine's maximum permissible rpm.

#### **Setting the idling speed (2,000 rpm):**

- It is usually necessary to change the setting of the idle speed adjusting screw (I) after every correction to the low speed adjusting screw (L).

#### **Engine stops whilst idling:**

- Turn the idle speed adjusting screw (I) clockwise until drilling spindle begins to rotate - then back off the screw one half turn.

#### **Drilling spindle rotates when engine is idling**

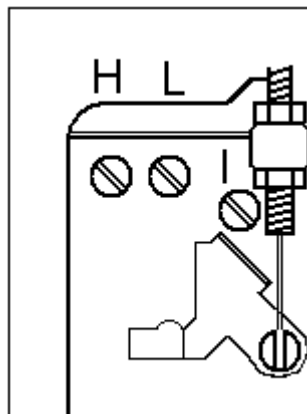

- Turn the idle speed adjusting screw (I) counter-clockwise until the drilling spindle stops rotating - then turn the screw approximately one half turn in the same direction.

#### **Erratic idling behaviour - poor acceleration**

- Idle setting is too lean. Turn the low speed adjusting screw (L) counter-clockwise until the engine runs and accelerates smoothly.

#### **Exhaust smokes at idling speed**

- Idle setting is too rich. Turn the low speed adjusting screw (L) clockwise until engine speed drops, then turn screw back one quarter turn and check that the engine accelerates smoothly when the throttle is opened.

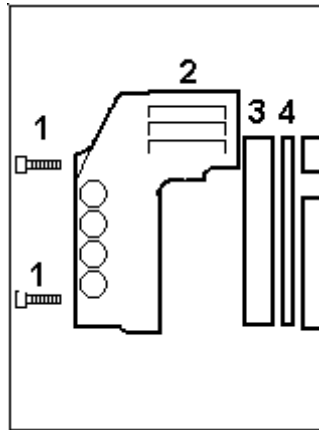

**CLEANING THE AIR FILTER****All day operation**

- Clean filter daily. If the work area is very dusty, clean more often.
- Turn choke knob to CHOKE. Take out screws (1), remove filter cover (2). Clean away dirt from around filter. Remove foam (3) and felt elements (4).
- Wash filter in clean, non-inflammable cleaning solution (e.g. warm soapy water) and then dry.
- Always replace a damaged filter element. Reinstall the filter.

**CHECKING THE SPARK PLUG**

- If the engine is down on power, difficult to start or runs poorly at idling speed, first check the spark plug.
- Fit a new spark plug after approximately 100 operating hours - or earlier if the electrodes are badly eroded.
- Remove the spark plug - see "**If engine doesn't start**" Clean dirty spark plug. Check electrode gap - it should be 0.5mm (0.020ins) - correct if necessary.
- Rectify faults which have caused fouling of spark plug - incorrect carburettor setting; too much oil in fuel mix; dirty air filter; unfavourable running conditions, e.g. operating at part load.

## REPLACING THE STARTER ROPE AND REWIND SPRING

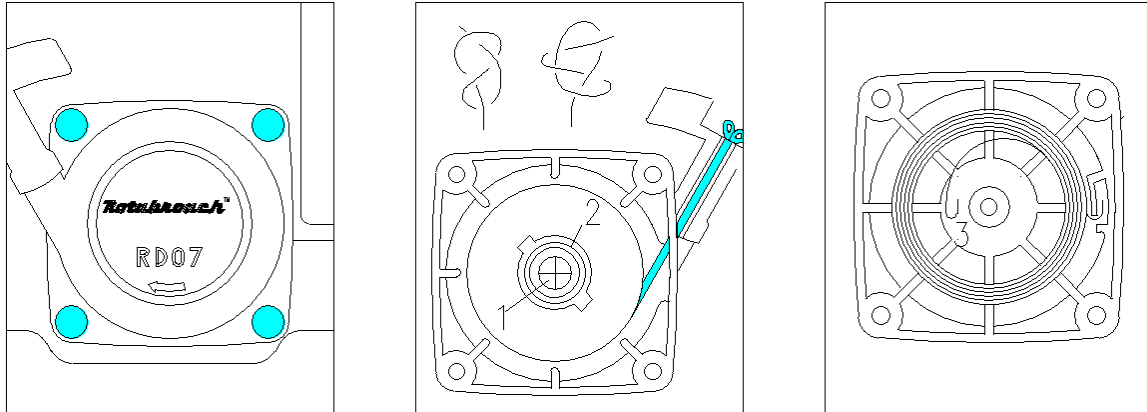

- Remove four screws and starter cover
- Take out screw (1) and pull off rope rotor with washer (2).
- Remove remaining rope from rotor, thread new rope  $\text{Ø}3.5\text{mm}$  (9/64") and 850mm (33½") long into the rotor and secure it with a simple overhand knot. Thread the other end from inside, through the rope guide bush and underside of the starter grip and secure with special knot - do not wind rope onto rotor.
- Coat rope rotor bearing bore with non-resinous oil, slide rotor onto starter post, turn it back and forth so that the anchor loop (3) of the rewind spring engages.
- Fit the washer and screw and tighten down firmly.

### Tensioning the rewind spring

- Make a loop in the starter rope and use it to turn the rope rotor six full revolutions counter-clockwise. Hold the rotor steady, straighten the twisted rope, release the rotor, then let go of the rope slowly so that it winds onto the rotor.
- The starter grip must locate firmly in the rope guide bush. If the grip droops to one side, add one more turn on the rope rotor to increase spring tension.
- When the starter rope is fully extended it must be possible to rotate the rotor at least another half turn. If this is not the case, the spring is over-tensioned and could break. Take off one turn of the rope.

### Replacing a broken rewind spring

- Lubricate the new spring with a few drops of non-resinous oil. **Do not open** the wire retainer.
- Remove the rope rotor. Remove the bits of the old spring and fit the new rewind spring with the outer spring loop in the recess at the bottom of the starter cover. The wire retainer slips off during this process.
- Reinstall the rope rotor, tension and rewind spring and secure the starter cover in position.
- If the spring pops out during installation, refit it in the counter-clockwise direction starting outside and working inwards.

# [11] EXPLODED VIEW OF ARBOR SPINDLE ASSEMBLY

From serial number 65820 onwards

EXPLODED VIEW OF ARBOR SPINDLE ASSEMBLY

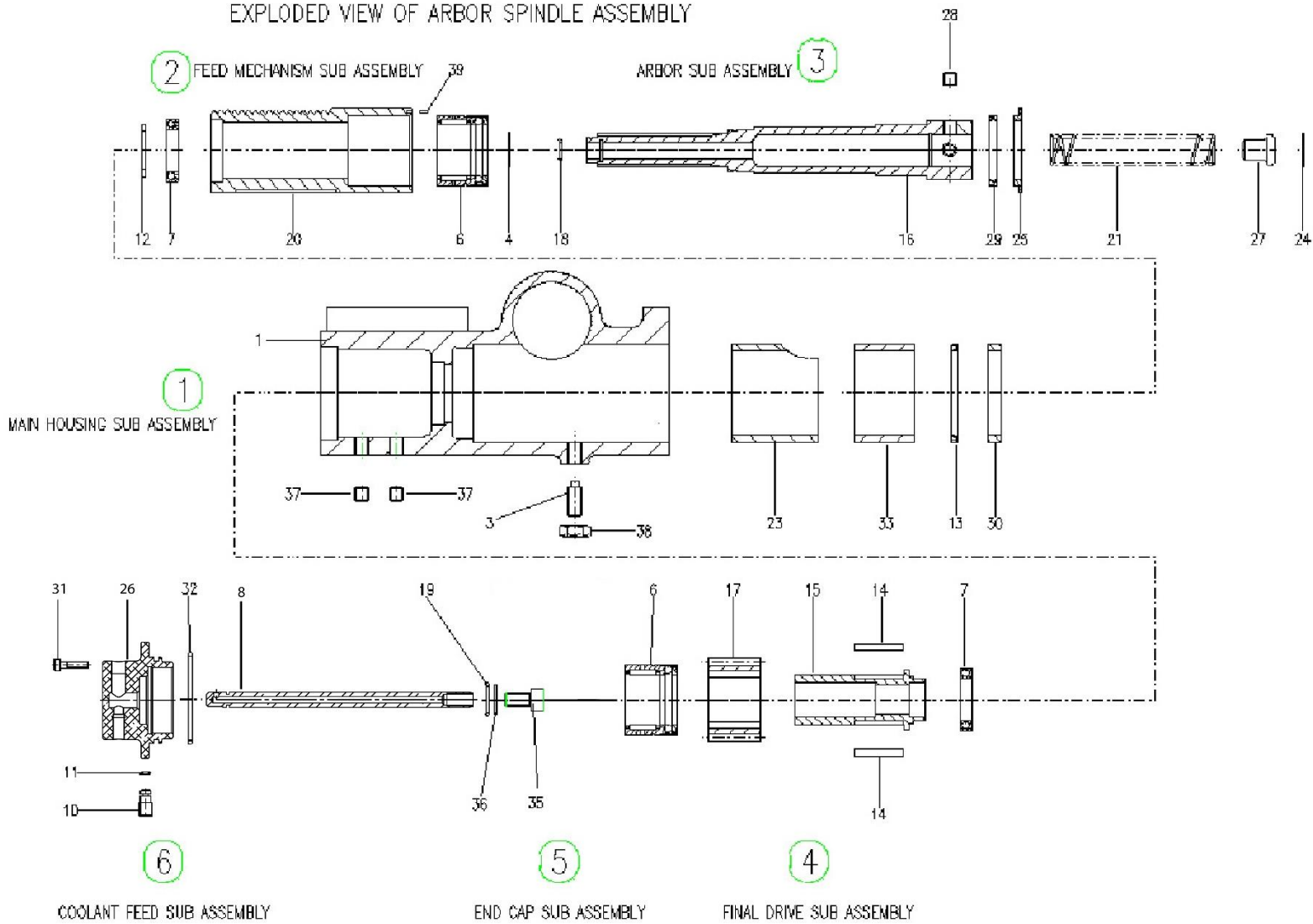

**[11] PARTS LIST FOR ARBOR AND SPINDLE ASSEMBLY** from serial number 65820 onwards

Item	Description	Part No	Quantity
1	MAIN HOUSING	RD3700	1
3	M8 x 25 DOG POINT SOCKET SCREW	RD4719	1
4	CIRCLIP	RM22876	1
6	COMBINED NEEDLE THRUST RACE	RD4700	2
7	BEARING	RD4701	2
8	COOLANT FEED TUBE	RD3793	1
10	COOLANT TUBE CLAMP SCREW	RD3713	1
11	'O' RING	RD4703	1
12	CIRCLIP	RD4713	1
13	OIL SEAL	RD4712	1
14	FINAL DRIVE KEY	RD4705	2
15	FINAL DRIVE SPINDLE	RD3707	1
16	ARBOR/SPINDLE	RD3704	1
17	FINAL DRIVE GEAR	RD3702	1
18	'O' RING	RD4706	1
19	'O' RING	RD47174	1
20	FEED TUBE	RD3701	1
21	SPRING	RA355	1
23	REAR BRONZE BEARING	RD3719	1
24	CIRCLIP	RD4056	1
25	FEED TUBE WEAR CAP	RD3714	1
26	SOLID END CAP AND COOLANT COMBINED HOUSING	RD37110	1
27	BUTTON	RA354	1
28	M8 SOCKET SCREW	RD4066	2
29	OILSEAL	RD4704	1
30	OILSEAL PROTECTION RING	RD3718	1
31	M4 C/SUNK SKT HD SCREW	RD47204	4
32	'O' RING	RD4709	1
33	FRONT BRONZE BEARING	RD4711	1
35	M8 x 15 CAPSCREW	RD4184	1
36	M8 WASHER	RD4078	1
*37	1/8" BSPT PLUG	RD4745	2
*38	M8 HEX NUT	RD4192	1
39	ROLL PIN	RD4740	1

\* Issue 3 (From models produced after serial number 59330)

# [12] EXPLODED VIEW OF ARBOR AND SPINDLE DRIVE

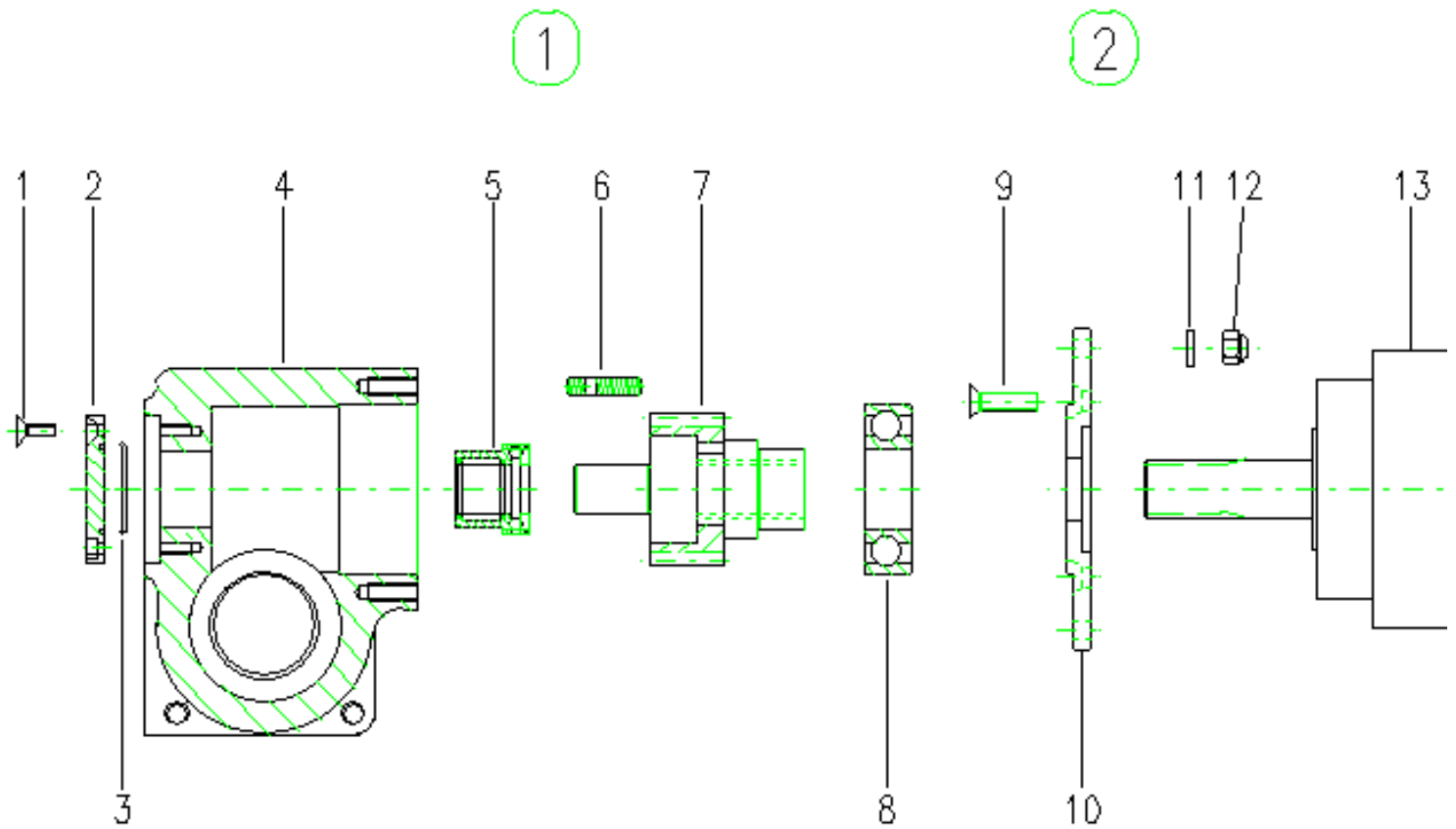

**[12.1] PARTS LIST FOR ARBOR AND SPINDLE DRIVE**

<b>Item</b>	<b>Description</b>	<b>Part No</b>	<b>Quantity</b>
1	M4 SKT HEAD CAPSCREW	RD4728	4
	M4 SHAKEPROOF WASHER	RD4069	4
2	VERTICAL DRIVE SHAFT COVER	RD3716	1
3	O'RING	RD4718	1
4	MAIN HOUSING	RD3700	1
5	COMBINED NEEDLE THRUST RACE	RD4714	1
6	M6 STUD	RD4340	4
7	INTERMEDIATE GEAR ASSEMBLY	RD3737	1
8	DOUBLE SEALED SINGLE ROW BRG	RD4725	1
9	M6X 20 C/SUNK CAP SCREW	RD4722	4
10	MOTOR MOUNTING FLANGE	RD3721	1
11	M6 FLAT WASHERS	RD4095	4
12	M6 NYLOC NUT	RD4223	4
13	STHIL PETROL MOTOR	RD5008	1

# [13] EXPLODED VIEW OF ARBOR AND SPINDLE FEED

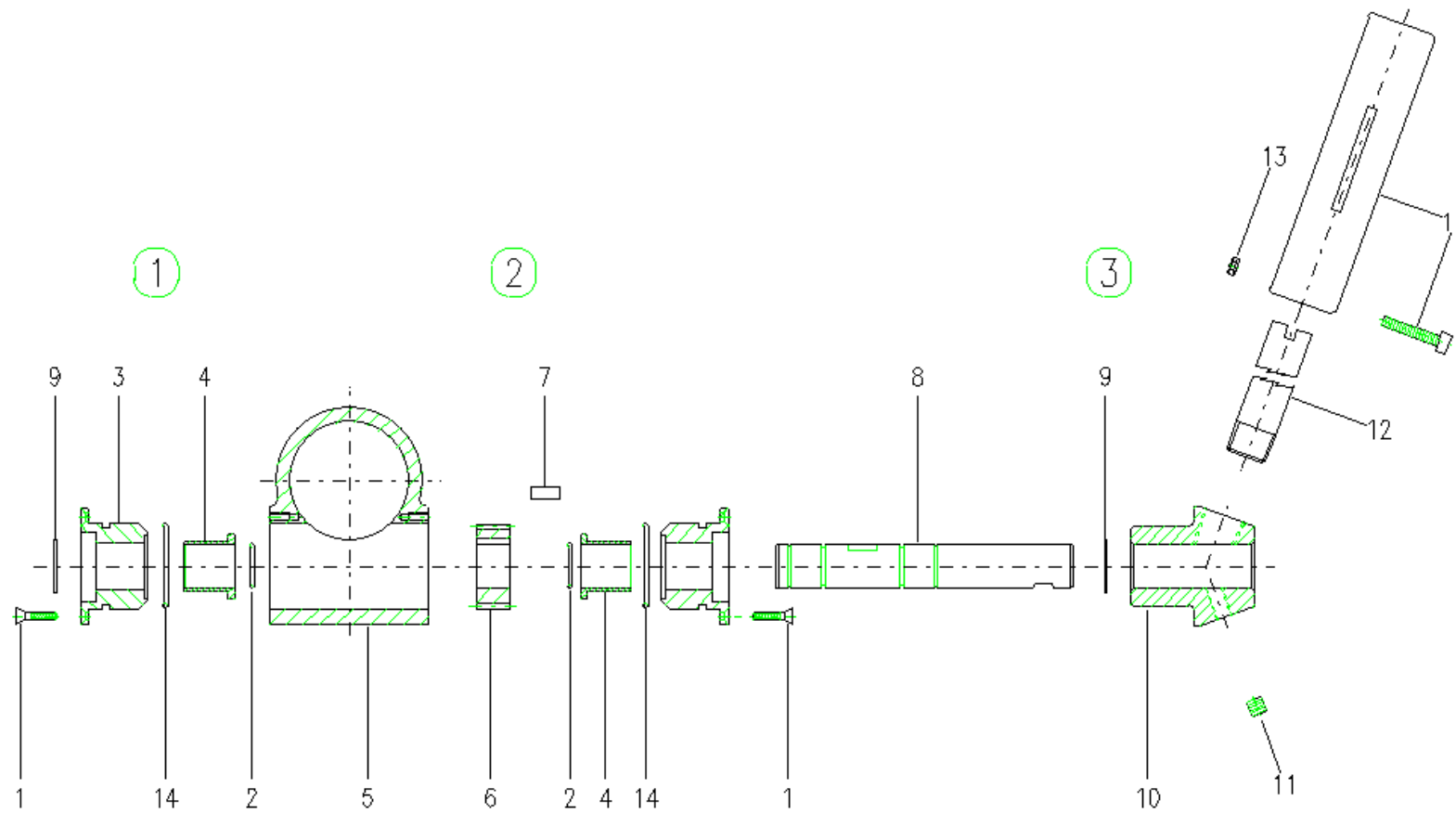



**[13.1] PARTS LIST FOR ARBOR AND SPINDLE DRIVE**

<b>Item</b>	<b>Description</b>	<b>Part No</b>	<b>Quantity</b>
1	M4 CAPSCREW	RD4721	4
2	O' RING	RD4726	2
3	CAPSTAN SPINDLE HOUSING	RD3712	2
4	FLANGED OILITE BUSH	RD4724	2
5	MAIN HOUSING	RD3700	1
6	FEED GEAR	RD3705	1
7	FEED GEAR KEY	RD4708	1
8	CAPSTAN SPINDLE	RD3758	1
9	CIRCLIP	RD4730	2
10	CAPSTAN HUB	RD3725	1
11	M8 x 20 DOGPOINT SOCKET SET SCREW	RD47199	1
12	CAPSTAN ARM	RD3727	1
13	CONTROL HANDLE OFF STIHL MOTOR		1
14	O' RING	RD4727	2
15	TYRAP	RD4353	2

[14] EXPLODED VIEW OF RAIL CLAMP ASSEMBLY

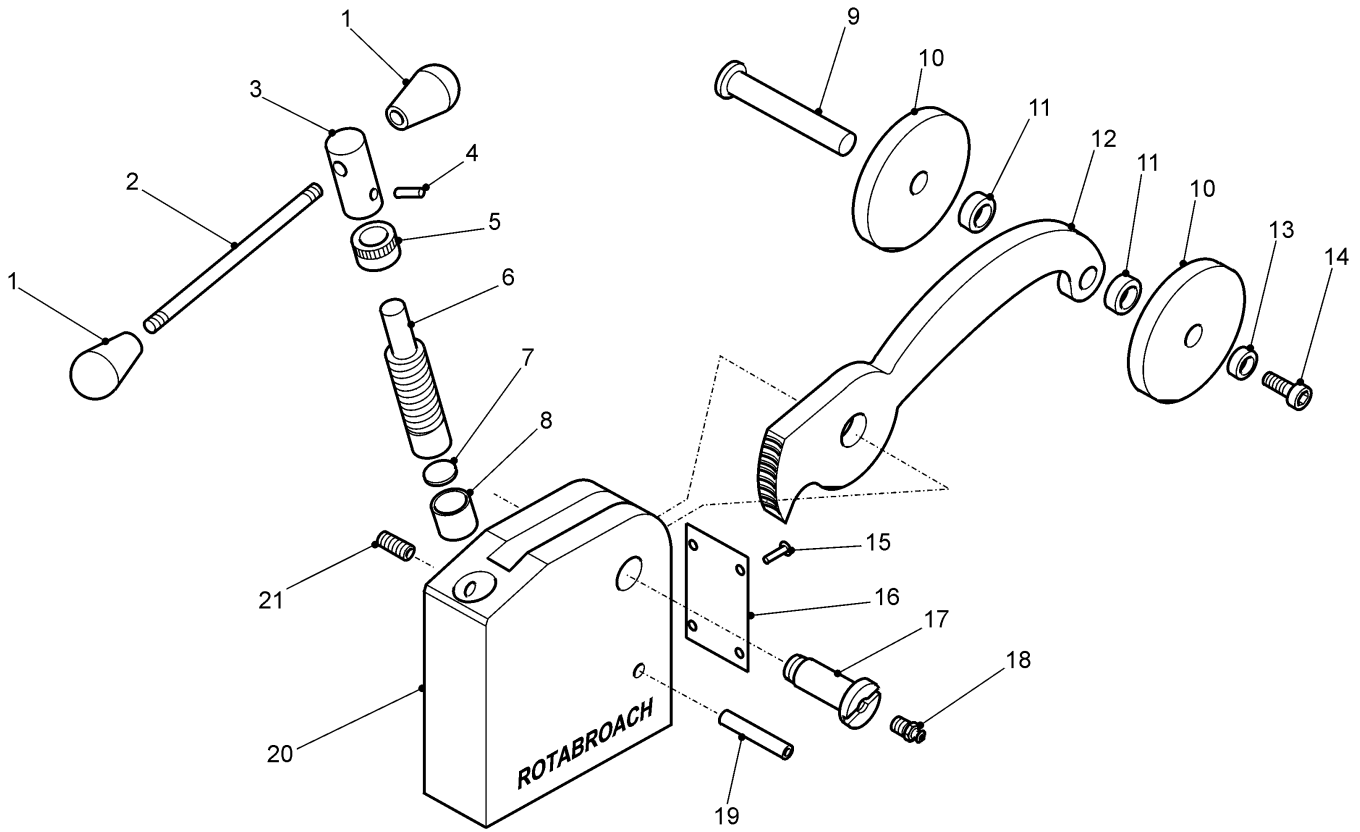

**[14.1] PARTS LIST FOR RAIL CLAMP ASSEMBLY**

<b>Item</b>	<b>Description</b>	<b>Part No</b>	<b>Quantity</b>
1	CAPSTAN KNOB	RY4060	2
2	CAPSTAN SPINDLE	RY4061	1
3	CAPSTAN	RY4062	1
4	PIN	RY4063	1
5	COLLAR	RY4064	1
6	WORM	RY4065	1
7	THRUST WASHER	RY4066	1
8	BEARING BUSH	RY4067	1
9	ROLLER PIN	RY4068	1
10	ROLLER	RY4069	2
11	DISTANCE PIECE	RY4070	2
12	CLAMP ARM	RY4071	1
13	COLLAR	RY4072	1
14	SCREW	RY4325	1
15	RIVET	RY4074	4
16	GUARD PLATE	RY4075	1
17	PIVOT PIN	RY4076	1
18	LUBRICATION NIPPLE	RY4077	1
19	ROLL PIN	RY4078	1
20	CLAMP BODY	RY4079	1
21	LOCK SCREW	RY4368	1

[14.2] EXPLODED VIEW OF QUICK RELEASE RAIL CLAMP ASSEMBLY

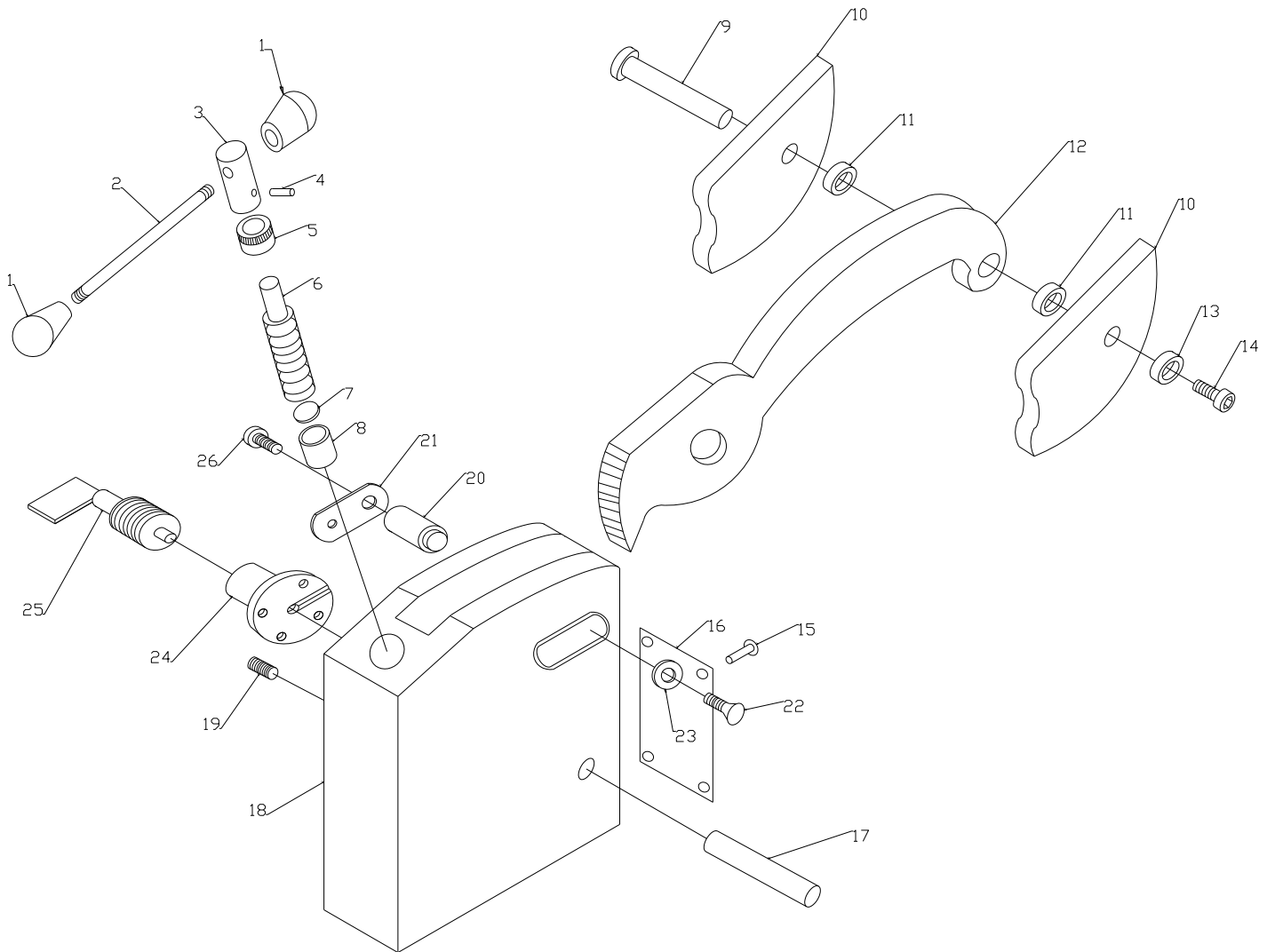

**[14.3] PARTS LIST FOR QUICK RELEASE RAIL CLAMP ASSEMBLY**

<b>Item</b>	<b>Description</b>	<b>Part No</b>	<b>Quantity</b>
1	CAPSTAN KNOB	RY4060	2
2	CAPSTAN SPINDLE	RY4061	1
3	CAPSTAN	RY4062	1
4	PIN	RY4063	1
5	COLLAR	RY4064	1
6	WORM	RY4065	1
7	THRUST WASHER	RY4066	1
8	BEARING BUSH	RY4067	1
9	ROLLER PIN	RY4068	1
10	ROLLER	RY4069	2
11	DISTANCE PIECE	RY4070	2
12	CLAMP ARM	RY4071	1
13	COLLAR	RY4072	1
14	SCREW	RD4325	1
15	RIVET	RY4074	4
16	GUARD PLATE	RY4075	1
17	ROLL PIN	RY4078	1
18	CLAMP BODY	RY33125	1
19	LOCK SCREW	RY4368	1
20	CONNECTING ROD	RY33126	1
21	SLIDE BAR	RY33127	1
22	COUNTERSUNK M5	RD4347	1
23	WASHER	RY33138	1
24	CLAMP CONNECTOR	RY33128	1
25	BALL PLUNGER	RY4095	1
26	M5 X 16 SOCKETHEAD	RD4325	1



## [15]WARRANTY STATEMENT

Rotabroach® warrants its machines to be free from faulty materials, or workmanship under normal use for a period of 12 months from initial date of purchase and 90 days for all other parts (excluding cutters), provided that the warranty registration card (or online registration) has been completed and returned to Rotabroach®, or its designated distributor within a period of (30) days from the purchase date, failure to do so will void the warranty. If the stated is adhered to Rotabroach® will repair or replace (at its option) without charge any faulty items returned.

### This Warranty does not cover:

1. Components that are subject to natural wear and tear caused by the use in accordance with the operators instructions
2. Defects in the tool caused by non-compliance with the operating instructions, improper use, abnormal environment conditions, inappropriate operating conditions overload or insufficient servicing or maintenance.
3. Defects caused by using accessories, components or spare parts other than original Rotabroach® parts.
4. Tools to which changes or additions have been made.
5. Electrical components are subject to manufacturer's warranty.

Your online registration can be submitted on [www.rotabroach.co.uk](http://www.rotabroach.co.uk)

The warranty claim must be lodged within the warranty period. This requires the submission or sending of the **complete** tool in question with the original sales receipt which must indicate the purchase date of the product. A complaint form must also be submitted prior to the return.

This can be found online at [www.rotabroach.co.uk](http://www.rotabroach.co.uk) Failure to complete this form will result in the delay of your claim.

All goods returned defective must be returned pre-paid to Rotabroach®, in no event shall Rotabroach® be liable for subsequent direct, or indirect loss or damage.

THIS WARRANTY IS IN LIEU OF ANY OTHER WARRANTY, (EXPRESSED OR IMPLIED) INCLUDING ANY WARRANTY OF MERCHANTABILITY OR FITNESS FOR A PARTICULAR PURPOSE. ROTABROACH® RESERVE THE RIGHT TO MAKE IMPROVEMENTS AND MODIFICATIONS TO DESIGN WITHOUT PRIOR NOTICE

**Known and Trusted Worldwide for Quality, Performance and Reliability**