

# ***Rotabroach***<sup>®</sup> **ELEMENT 100**

**Magnetic drilling & tapping machine**

**Model Number Element 100/1T, Element 100/3T**

**This machine (Serial Number .....) is CE approved.**



***Rotabroach***<sup>®</sup>

**OSL Cutting Technologies  
Burgess Road  
Sheffield, South Yorkshire  
United Kingdom  
S9 3WD**

**Tel: +44 (0) 114 2212 510  
Email: [info@rotabroach.co.uk](mailto:info@rotabroach.co.uk)**

**Fax: +44 (0) 114 2212 563  
Website: [www.rotabroach.co.uk](http://www.rotabroach.co.uk)**

**Thank you for purchasing our Element 100 magnetic drill.  
We would really like your feedback on the machine.**

***Other products by Rotabroach:***

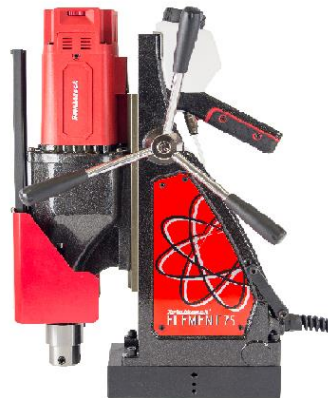

**Thank you for your purchase of our product.**

## CONTENTS OF THE MANUAL

	Page
1) Intended use	4
2) General safety rules	4
3) Information plate symbols	5
4) Specification	6
5) Operational safety procedures	7
6) Operating instructions	8
7) Control panel operation	9
8) Tapping function	10
9) Gear selection	11
10) Magnet detection	11
11) Extension cable selection	12
12) Mounting of cutters	12
13) Capstan operation	12
14) Remedies for hole making problems	13
15) Wiring diagram	14
16) Exploded view of machine	16
17) Exploded view of motor and gearbox	17
18) Control panel parts and list	22
19) Pipe adapter kit RD2311	23
20) Fitting the chuck	24
21) Maintenance	25
22) Trouble shooting	26
23) Cutter selection and speeds	27
24) Warranty and CE statements	28

P/N	List of Contents with Magnetic Drill Unit
RDD4126	16mm Chuck
CA130	Arbor assembly – 6mm hexagonal spanner included
RDA3105	Safety glasses
RDD4128	Arbor shank
RDD4129	Drift
RDC4083	Safety belt
RD4152	3mm hexagonal spanner
RDC4082	stationary rings
RDD4132	Spare brush-230V
RDD4133	Spare brush-110V
RA3122	Pilot pin

## 1) INTENDED USE

The intended use of this magnetic drill is to drill holes in ferrous metals. The magnet is used to hold the drill in place whilst the drill is functioning. It is designed for use in fabrication, construction, railways, petrochemical and any other applications when drilling ferrous metal.

Any deviation from its intended use will not be covered by warranty.

## 2) GENERAL SAFETY RULES

**WARNING!** Read all safety warnings, instructions, illustrations, and specifications provided with this power tool. Failure to follow all instructions listed below may result in electric shock, fire, and/or serious injury.

**Save all warnings and instructions for future reference.**

The term "power tool" in the warnings refers to your mains-operated (corded) power tool or battery-operated (cordless) power tool.

### Work area safety

**Keep work area clean and well lit.** Cluttered or dark areas invite accidents.

**Do not operate power tools in explosive atmospheres, such as in the presence of flammable liquids, gases or dust.** Power tools create sparks which may ignite the dust or fumes.

**Keep children and bystanders away while operating a power tool.** Distractions can cause you to lose control.

### Electrical safety

**a) Power tool plugs must match the outlet. Never modify the plug in any way. Do not use any adapter plugs with earthed (grounded) power tools.** Unmodified plugs and matching outlets will reduce risk of electric shock.

**b) Avoid body contact with earthed or grounded surfaces, such as pipes, radiators, ranges and refrigerators.** There is an increased risk of electric shock if your body is earthed or grounded.

**c) Do not expose power tools to rain or wet conditions.** Water entering a power tool will increase the risk of electric shock.

**d) Do not abuse the cord. Never use the cord for carrying, pulling or unplugging the power tool. Keep cord away from heat, oil, sharp edges or moving parts.** Damaged or entangled cords increase the risk of electric shock.

**e) When operating a power tool outdoors, use an extension cord suitable for outdoor use.** Use of a cord suitable for outdoor use reduces the risk of electric shock.

**f) If operating a power tool in a damp location is unavoidable, use a residual current device (RCD) protected supply.** Use of an RCD reduces the risk of electric shock.

NOTE The term "residual current device (RCD)" can be replaced by the term "ground fault circuit interrupter (GFCI)" or "earth leakage circuit breaker (ELCB)".

### Personal safety

**a) Stay alert, watch what you are doing and use common sense when operating a power tool. Do not use a power tool while you are tired or under the influence of drugs, alcohol or medication.** A moment of inattention while operating power tools may result in serious personal injury.

**b) Use personal protective equipment. Always wear eye protection.** Protective equipment such as a dust mask, non-skid safety shoes, hard hat or hearing protection used for appropriate conditions will reduce personal injuries.

**c) Prevent unintentional starting. Ensure the switch is in the off-position before connecting to power source and/or battery pack, picking up or carrying the tool.** Carrying power tools with your finger on the switch or energising power tools that have the switch on invites accidents.

**d) Remove any adjusting key or wrench before turning the power tool on.** A wrench or a key left attached to a rotating part of the power tool may result in personal injury.

**e) Do not overreach. Keep proper footing and balance at all times.** This enables better control of the power tool in unexpected situations.

**f) Dress properly. Do not wear loose clothing or jewellery. Keep your hair and clothing away from moving parts.** Loose clothes, jewellery or long hair can be caught in moving parts.

**g) If devices are provided for the connection of dust extraction and collection facilities, ensure these are connected and properly used.** Use of dust collection can reduce dust-related hazards.

**h) Do not let familiarity gained from frequent use of tools allow you to become complacent and ignore tool safety principles.** A careless action can cause severe injury within a fraction of a second

**Power tool use and care**

- a) **Do not force the power tool. Use the correct power tool for your application.** *The correct power tool will do the job better and safer at the rate for which it was designed.*
- b) **Do not use the power tool if the switch does not turn it on and off.** *Any power tool that cannot be controlled with the switch is dangerous and must be repaired.*
- c) **Disconnect the plug from the power source and/or remove the battery pack, if detachable, from the power tool before making any adjustments, changing accessories, or storing power tools.** *Such preventive safety measures reduce the risk of starting the power tool accidentally.*
- d) **Store idle power tools out of the reach of children and do not allow persons unfamiliar with the power tool or these instructions to operate the power tool.** *Power tools are dangerous in the hands of untrained users.*
- e) **Maintain power tools and accessories. Check for misalignment or binding of moving parts, breakage of parts and any other condition that may affect the power tool’s operation. If damaged, have the power tool repaired before use.** *Many accidents are caused by poorly maintained power tools.*
- f) **Keep cutting tools sharp and clean.** *Properly maintained cutting tools with sharp cutting edges are less likely to bind and are easier to control.*
- g) **Use the power tool, accessories and tool bits etc. in accordance with these instructions, taking into account the working conditions and the work to be performed.** *Use of the power tool for operations different from those intended could result in a hazardous situation.*
- h) **Keep handles and grasping surfaces dry, clean and free from oil and grease.** *Slippery handles and grasping surfaces do not allow for safe handling and control of the tool in unexpected situations.*

**Service**

**Have your power tool serviced by a qualified repair person using only identical replacement parts.** *This will ensure that the safety of the power tool is maintained*

**3) INFORMATION PLATE SYMBOLS**

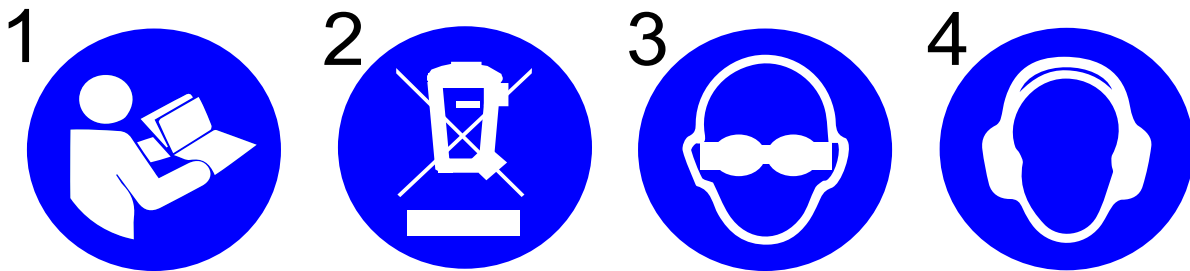

- 1. Refer to the user manual for operational and safety issues regarding this machine.
- 2. Dispose of the machine and electrical components correctly.
- 3. Eye protection must be worn when operating the machine.
- 4. Ear defenders must be worn when operating the machine.

**4) SPECIFICATION**

Maximum hole cutting capacity in .2/.3C steel = 100mm dia. x 100mm deep  
 Arbor bore = MT3.

<b>Motor Unit</b>		
Voltages	110V 50-60Hz	230-240V 50-60Hz
Normal full load	2000 W	2000 W
<b>Electro Magnet</b>	96W	109W
Size	228mm long 114mm wide	
Holding Force at 20°C with 25mm minimum plate thickness <b>The use on any material less than 25mm thick will progressively reduce the magnetic performance. If possible, substitute material should be positioned under the magnet and work piece to equate to a suitable material thickness. If this is not possible, an alternative secure method of restraining the machine must be used.</b>	20000N	
<b>Overall Dimensions</b>		
Height - maximum extended	733mm	
Height - minimum	533mm	
Width (including capstan fitting)	230mm	
Length Overall (including guard)	370mm	
<b>Nett Weight</b>	24.8kgs	24.5kgs
	Element 100/1T	Element 100/3T
Vibration total values (triax vector sum) in accordance with EN62841-1:	Vibration emission value (a <sub>v</sub> ):3.862m/s <sup>2</sup> Uncertainty(K):1.5m/s <sup>2</sup>	Vibration emission value (a <sub>h</sub> ):3.824 m/s <sup>2</sup> Uncertainty(K):1.5m/s <sup>2</sup>
Level of sound pressure in accordance with EN62841-1:	<i>Sound pressure(LpA):</i> 89.0 dB(A) <i>Acoustic power(LwA):</i> 102.0 dB(A) Uncertainty(K): 3dB(A)	<i>Sound pressure(LpA):</i> 88.0 dB(A) <i>Acoustic power(LwA):</i> 101.0 dB(A) Uncertainty(K) : 3dB(A)

**Vibration and Noise**

The declared vibration total value(s) and the declared noise emission value(s) have been measured in accordance with a standard test method and maybe used for comparing one tool with another.

The declared vibration total value(s) and declared noise emission values(s) may also be used in a preliminary assessment of exposure.

The vibration and noise emissions during actual use of the power tool can differ from the declared total value depending on the ways in which the tool is used and especially what kind of workpiece is being processed

The need to identify safety measures to protect the operator that are based on an estimation of exposure in the actual conditions of use (taking account of all parts of the operating cycle such as the times when the tool is switched off and when it is running idle in addition to the trigger time).

Ear and eye defenders must be worn when operating this machine. Wear gloves to protect hands when operating the machine.

These tools are UK designed and manufactured with globally sourced components and conform to the requirements of EEC Document HD.400.1 and BS.2769/84

**Suitable only for a single phase 50-60Hz A.C. power supply**

**DO NOT USE ON .C.SUPPLY**

**Do not use your magnetic drill on the same structure when arc welding is in progress.**

**D.C. current will earth back through the magnet and cause irreparable damage.**

**WARNING: THIS APPLIANCE MUST BE EARTHED!**

**NB: ANY MODIFICATIONS TO THIS MACHINE WILL INVALIDATE THE GUARANTEE**

## 5) OPERATIONAL SAFETY PROCEDURES

### READ BEFORE USING THE MACHINE

- Always take care when lifting and transporting this machine. The maximum lifting weight for one person is 25kgs. See Fig.1
- When using electrical tools, basic safety precautions should always be followed to reduce the risk of electric shock, fire, and personal injury.
- Ensure the magnet is OFF before plugging in the machine.
- Do NOT use in wet or damp conditions. Failure to do so may result in personal injury.
- Do NOT use in the presence of flammable liquids, gases or in high risk environments. Failure to do so may result in personal injury.
- BEFORE activating the machine, inspect all electrical supply cables (including extension leads), and replace if damaged. DO NOT use if there are any signs of damage.
- Only use extension cables approved for site conditions.
- BEFORE activating the machine, ALWAYS check the correct function of all operational systems, switches, magnet etc.
- BEFORE operating, the machine MUST be securely restrained to a fixed independent feature (by using safety strap RD4329B, or other means) to reduce the potential free movement, should the magnet become detached from the work piece. Failure to do so may result in personal injury.
- ALWAYS wear approved eye protectors, ear defenders and recommended PPE at ALL times when operating the machine.
- Disconnect from power source when changing cutters or working on the machine.
- Cutters and swarf are sharp, ALWAYS ensure that hands are adequately protected when changing cutters or removing swarf. Use a tool or brush where necessary to remove any swarf or the cutter from the arbor.
- Before operating the machine, ALWAYS ensure cutter-retaining screws are secured tightly.
- Regularly clear the work area and machine of swarf and dirt, paying particular attention to the underside of the magnet base.
- ALWAYS remove tie, rings, watches and any loose adornments that might entangle with the rotating machinery before operating.
- ALWAYS ensure that long hair is securely enclosed by an approved restraint before operating the machine.
- Should the cutter become stuck in the work piece, stop the motor immediately to prevent personal injury. Disconnect from power source and turn arbor to and fro. DO NOT ATTEMPT TO FREE THE CUTTER BY SWITCHING THE MOTOR ON AND OFF. Wear safety gloves to remove the cutter from the arbor.
- If the machine is accidentally dropped, ALWAYS thoroughly examine the machine for signs of damage and check that it functions correctly BEFORE resuming drilling.
- Regularly inspect the machine and check for any damaged or loose parts.
- ALWAYS ensure when using the machine in an inverted position that only the minimum amount of coolant is used, and that care is taken to ensure that coolant does not enter the motor unit.
- Cutting tools may shatter, ALWAYS position the guard over the cutter before activating the machine. Failure to do so may result in personal injury.
- On completion of the cut, a slug will be ejected. DO NOT operate the machine as the ejected slug may cause injury.
- When not in use ALWAYS store the machine in a safe and secure location.
- ALWAYS ensure that approved ROTABROACH™ agents conduct repairs.



Fig.1

## 6) OPERATING INSTRUCTIONS

Keep the inside of the cutter clear of swarf. It restricts the operating depth of the cutter.

- Ensure that the coolant bottle contains sufficient cutting oil to complete the required operating duration. Refill as required.
- Occasionally depress the pilot to ensure cutting fluid is being correctly metered.
- To start the machine, follow the control panel operation instructions.
- ALWAYS switch off the motor by depressing the MOTOR stop button. DO NOT switch off the motor by depressing the MAGNET switch.
- Apply light pressure when commencing the cut of a hole until the cutter is introduced into the work surface. Pressure can then be increased sufficiently to load the motor. Excessive pressure is undesirable, it does not increase the speed of penetration and will cause the safety overload protection device to stop the motor, (the motor can be restarted by operating the motor start button), and may cause excessive heat which may result in inconsistent slug ejection
- Always ensure that the slug has been ejected from the previous hole before commencing to cut the next.
- If the slug sticks in the cutter, move the machine to a flat surface, switch on the magnet and gently bring the cutter down to make contact with the surface. This will usually straighten a cocked slug and allow it to eject normally.
- Apply a small amount of light oil lubricant regularly to the slide and arbor support bearing.
- Cutter breakage is usually caused by insecure anchorage, a loosely fitting slide or a worn bearing in the arbor support. (Refer to routine maintenance instructions).
- Only use approved cutting fluid. Rotabroach cutting fluid has been specially formulated to maximise the cutters performance. It is available in 1 litre (RD208) and 5 litre (RD229).



1. Unscrew the cap
2. Pour neat oil into the coolant bottle
3. Screw the cap back on the bottle firmly
4. Open the tap.

Fig.2



## 7) CONTROL PANEL OPERATION

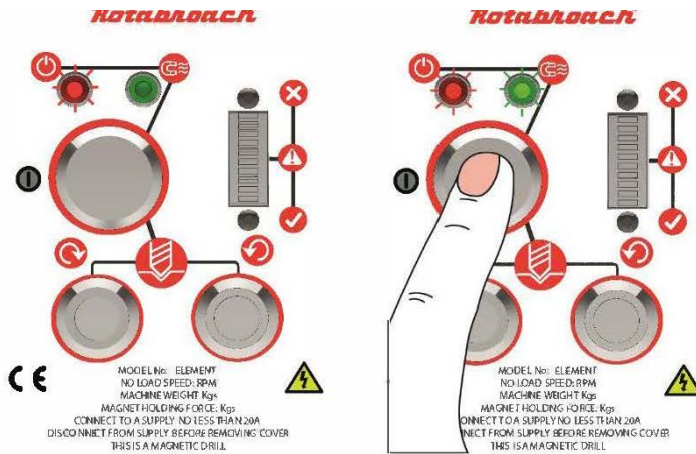

**1) Power**  
When the drill is connected to the power supply, the RED LED will indicate power to the drill.

**2) Magnet ON**  
To turn the magnet ON or OFF, press the large button on the control panel. The LED will illuminate either GREEN or RED depending on material thickness.

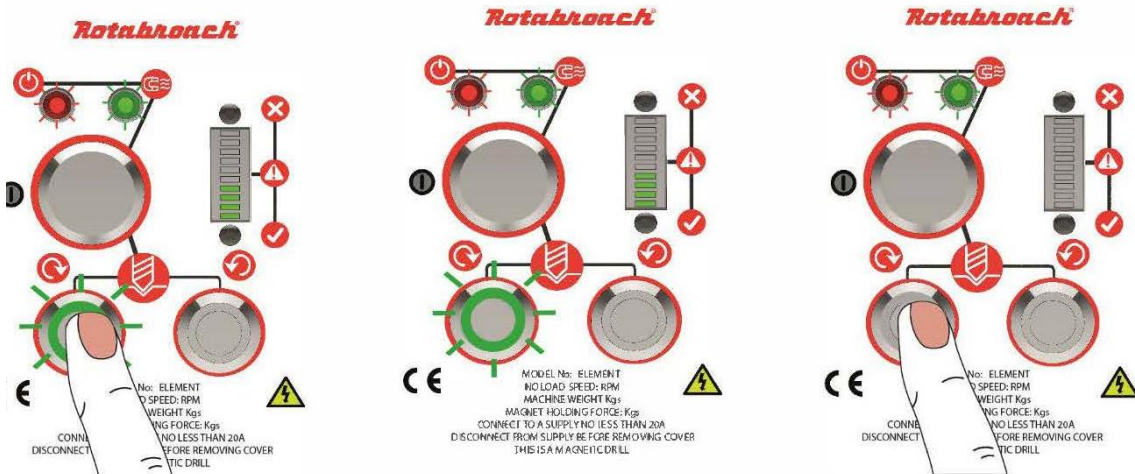

**3) Motor ON**  
Press the GREEN switch to turn the motor on. Proceed with cutting- following all safety guidelines.

**4) Cutting**  
See below for detailed description of the CutSmart™ visual indicator.

**5) Motor OFF**  
To stop the motor press the GREEN switch. The motor will stop and the magnet will remain on. The GREEN switch will turn off.

Go back to step 3 to start over.

### CutSmart™ Technology



**Green Zone**  
Perfect, try to keep in the green zone for the best cut and optimum machine performance.

**Yellow Zone**  
A little too much pressure on the drill ease off to get back to the green zone.

**Red Zone**  
Overload: Back off immediately as too much force will cause the motor to cut off if you continue.

### CutSmart™ Technology

Designed for you to get the most out of your machine and your cutters. CutSmart has an easy to read panel that indicates when you are drilling with too much force, which will damage the machine and the cutters.

Allow the cutter to do the work and you will find that a much smoother hole and faster drilling time is achieved.

## 8) TAPPING FUNCTION



1. Ensure power to the machine, red LED will illuminate (1).
2. Press the magnet switch on (2) to engage the magnet. The LED will light up in either green or red (3). Depending on the material thickness and magnetic adhesion. Green magnet LED indicates optimum adhesion achieved. Drilling operation is available.
- Warning** if red magnet LED is illuminated this indicates optimum adhesion not achieved. Drilling operation is still available.
3. Use the speed controller on the top cap housing to dictate the speed, always use speeds that are recommended for the drill size being used.
4. Turn the motor on in the forward direction (4).
5. Drill the hole to the recommended tapping size for the thread to be cut.
6. Without disengaging the magnet replace the drill with the tap.
7. Set the spindle speed to the required tapping speed required.
8. Start the drill spindle in the forward direction (4) and feed the tap into the hole until it begins to cut. Once cutting the tap will feed itself through, only gentle pressure on the feed handles should be necessary.
9. Once the tap has threaded the hole the drill should be stopped immediately (4).
10. The drill spindle should then be switched to reverse (5) and the tap can be fed back out of the hole. allows the tap to be safely extracted from the hole at a reduced RPM.

## 9) GEAR SELECTION

The Element 100 magnetic drill is fitted with a 4 speed gearbox. The gear is used to reduce the output speed when using larger cutters.

Slide Selector Position		Speed Controller Setting	
Left	Right	Level 1	Level 6
∨	∧	45/min	129/min
∨	∨	70/min	208/min
∧	∧	150/min	434/min
∧	∨	240/min	700/min

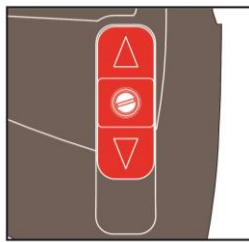

Slide Selector Positon Left

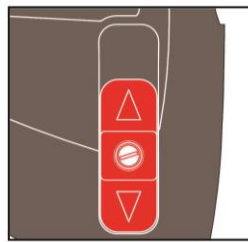

Slide Selector Position Right

The Slide Selector Positions show Left  $\wedge$  and Right  $\vee$  depicting an available range of 240 – 700/min.

## 10) MAGNET DETECTION

It is advised that when working on thin material a packing piece should be used to increase the material thickness under the magnet. Working on thin material without a packing piece will reduce the magnet holding force.

It is advised that the drill is to be operated on ferrous material 12mm thick and above. Damage to the magnet base, such as pitting, will affect the strength of the magnet holding force.

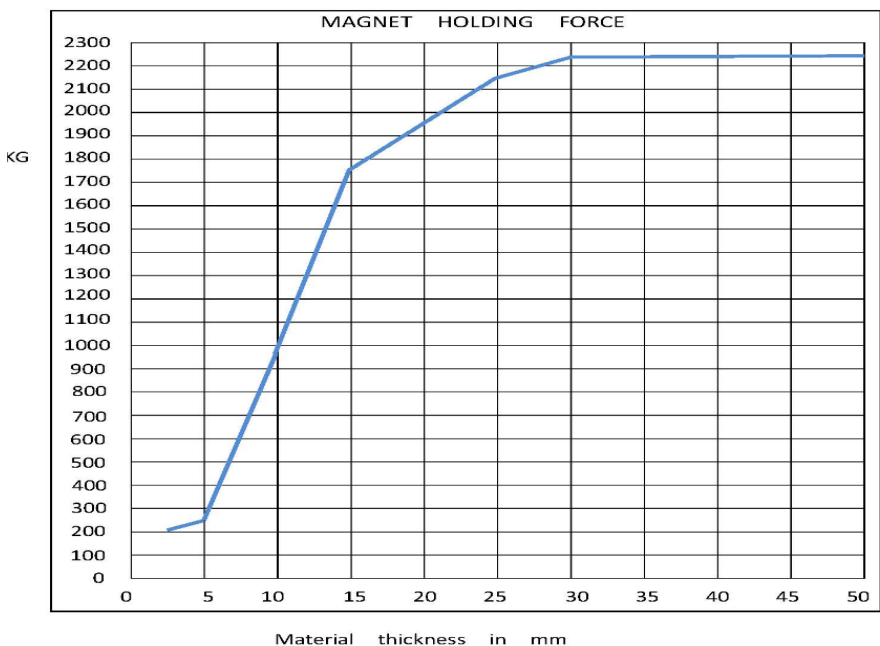

## 11) EXTENSION CABLE SELECTION

The machines are factory fitted with a 3-metre length of cable having three conductors 2.5mm<sup>2</sup> LIVE, NEUTRAL and EARTH. If it becomes necessary to fit an extension cable from the power source, care must be taken in using a cable of adequate capacity. Failure to do so will result in a loss of traction by the magnet and a reduction of power from the motor. Should the mains cable become damaged and need replacing, please ensure this is carried out only by an approved Rotabroach Engineer.

Assuming a normal AC supply of the correct voltage, it is recommended that the following extension lengths shall not be exceeded:

**For 110v supply: 3.5metres of 3 core x 2.5mm<sup>2</sup>**

**For 230v supply: 26metres of 3 core x 1.5mm<sup>2</sup>**

**ALWAYS DISCONNECT THE MACHINE FROM THE POWER SOURCE BEFORE CHANGING CUTTERS.**

## 12) MOUNTING OF CUTTERS

- The machine has been made to accept cutters having 19.05mm (3/4") & 31.75mm (1 1/4") dia. Weldon shanks. The following procedure is to be used when mounting cutters:
- With the machine in the upright position, ensure the Arbor Assembly (CA130) is fully inserted into Arbor Spindle (RDD4022).
- Take appropriate pilot and place through the hole in cutter shank. Insert shank of cutter into bore of Arbor Assembly, ensuring alignment of two drive flats with socket screws.
- Tighten both screws using hexagon key.

## 13) CAPSTAN OPERATION

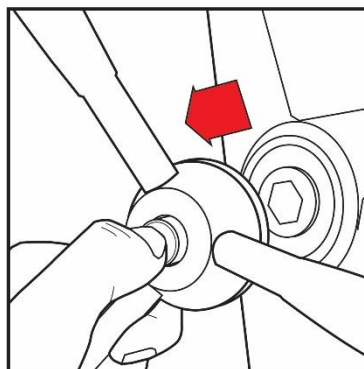
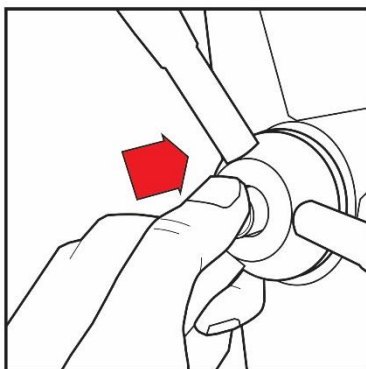

The quick release capstan is a feature that offers the user simple dual side operation.

To remove the capstan, simply do the following;

- 1: Press in the central button on the capstan hub, holding onto the capstan arms.
- 2: With the button pressed in, pull the capstan away from the main body, holding on to the capstan arms.

3: Re-insert the hexagonal shaft into the hexagonal slot to attach the capstan.

## 14) REMEDIES FOR HOLE MAKING PROBLEMS

<i>Problem</i>	<i>Cause</i>	<i>Remedy</i>
1) Magnetic base won't hold effectively	Material being cut may be too thin for efficient holding.  Swarf or dirt under magnet.  Irregularity on magnet contact or work-piece.  Insufficient current going to magnet during drilling cycles.	Attach an additional piece of metal under the magnet, or mechanically clamp magnetic base to work-piece.  Clean magnet.  Use extreme care; file any imperfections flush to surface.  Confirm power supply and output from control unit, check supply cable.
2) Cutter skips out of centre-punch mark at initiation of cut	Magnetic base is not holding effectively.  Worn arbor bushing and/or ejector collar.  Too much feed pressure at start of cut.  Cutter is dull, worn, chipped or incorrectly sharpened.  Poor centre-punch mark; weak pilot spring; pilot not centred in centre-punch mark.  Worn or bent pilot, worn pilot hole.  Loose bolts on motor bushing support bracket, main casting or loose gib adjusting set screws.	See causes and remedies above.  New arbor bushing is needed.  Light pressure only is needed until a groove is cut. The groove then serves as a stabilizer.  Replace or re-sharpen. Sharpening service is available.  Improve centre-punch and/or replace worn parts  Replace part or parts  Adjust where necessary
3) Excessive drilling pressure required	Incorrectly re-sharpened, worn or chipped cutter.  Coming down on swarf lying on surface of work-piece.  Gibstrips out of adjustment or lack of lubrication.  Swarf accumulated (packed) inside cutter.	Re-sharpen or replace.  Take care not to start a cut on swarf.  Adjust setscrews and lubricate.  Clear cutter.
4) Excessive cutter breakage	Steel swarf or dirt under cutter.  Incorrectly re-sharpened or worn cutter.  Cutter skipping.  Slide needs adjustment.  Cutter not attached tightly to arbor.  Insufficient use of cutting oil or unsuitable type of oil.  Incorrect speed	Remove cutter, clean part thoroughly and replace.  Always have a new cutter on hand to refer to for correct tooth geometry, together with instruction sheet.  See causes and remedies (2).  Tighten grub screws supporting the slide.  Retighten.  Inject oil of light viscosity into the coolant-inducing ring and check that oil is being metered into cutter when pilot is depressed. If not, check pilot groove and arbor internally for dirt or apply oil externally. (Even a small amount of oil is very effective).  Ensure correct gear is used for the cutter.
5) Excessive cutter wear	See cause and remedy above  Incorrectly re-sharpened cutter.  Insufficient or spasmodic cutting pressure.	Refer to instructions and a new cutter for proper tooth geometry.  Use sufficient steady pressure to slow the drill down. This will result in optimum cutting speed and chip load.

**15) WIRING DIAGRAM**

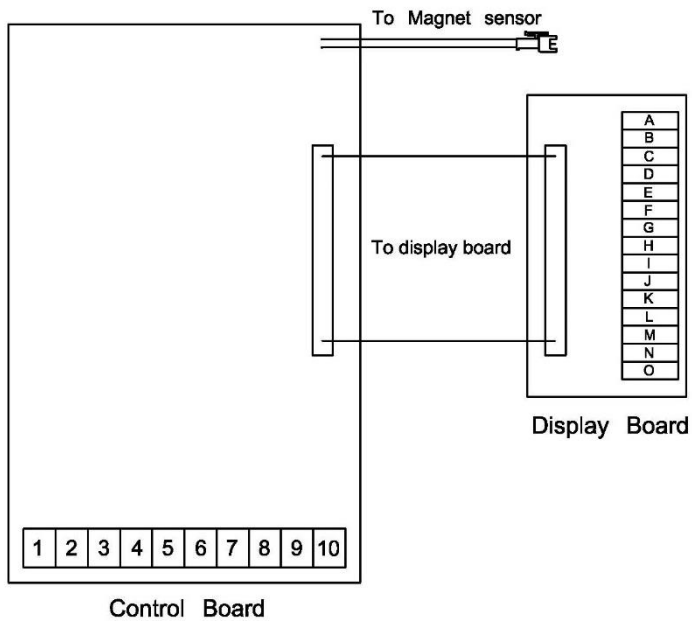

No	Function	Wire Colour
1	Mains Live Input	Brown
2	Speed controller module Lead wire	Yellow
3	Speed controller module Lead wire	Red
4	Mains Neutral Input	Blue
5	Magnet Positive Output	230V Red, 110V Blue
6	Magnet Negative Output	Brown
7	Field coil Lead wire	Blue
8	Field coil Lead wire	Green
9	Carbon brush Lead wire	Black
10	Carbon brush Lead wire	Brown

No	Function	Wire Colour
A	Motor 'Reverse' Switch 0V	White
B	Motor 'Reverse' Switch +5V	White
C	Motor 'Forward' Switch 0V	White
D	Motor 'Forward' Switch +5V	White
E	Magnet Switch 0V	White
F	Magnet Switch +5V	White
G	Magnet 'ON' LED +5V	White + Green
H	Magnet 'ON' LED +5V	White + Red
I	Magnet 'ON' LED 0V	White + Brown
J	Power 'ON' LED 0V	White + Black
K	Power 'ON' LED +5V	White + Brown
L	Motor 'Reverse' LED 0V (BLUE)	White
M	Motor 'Reverse' LED +12V (BLUE)	White
N	Motor 'Forward' LED 0V (Green)	White
O	Motor 'Forward' LED +12V (Green)	White

# 16) EXPLODED VIEW OF MACHINE

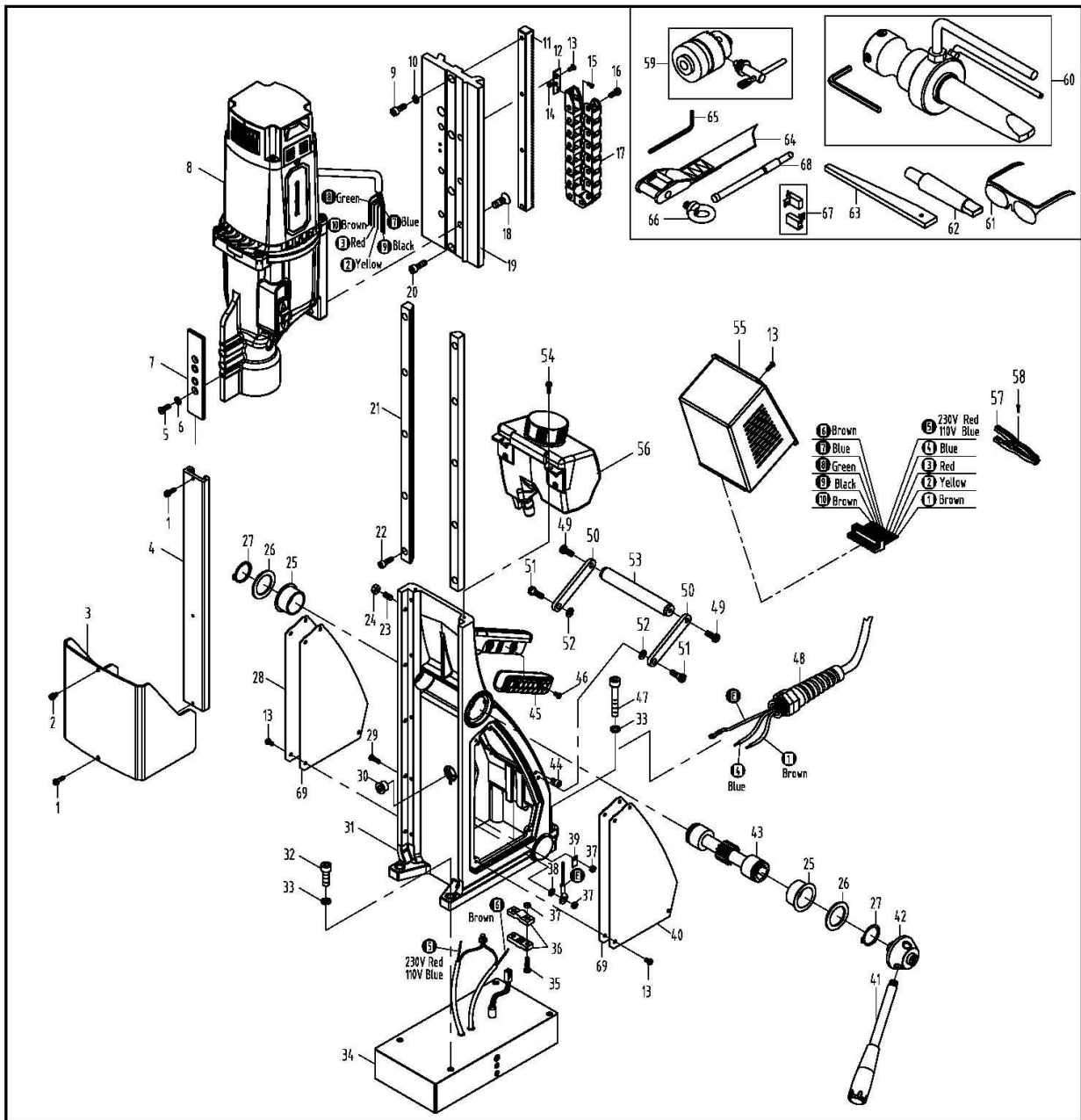





**PARTS LIST**

Item#	Rotabroach P/N	Description	Qty/pcs
1	RDA4201	Screw M4×14 Button Head	2
2	RDC4004	Screw M4×8 Button Head	1
3	RDD4014	Element 75 Guard	1
4	RDE4020	Slide channel	1
5	RDC4001	Screw M5×12 CSK HD	2
6	RD45607	M5 CSK Washer	2
7	RDD4017	Guard support	1
9	RDA4029	Screw M6×16 CAP HD	3
10	RDC4104	Spring washer	3
11	RDE4090	Rack	1
12	RDC4065	Cable chain attachment	1
13	RDA4021	Screw M4×8 Button Head	14
14	RDA4205	M3 Nut	2
15	RDA4204	Screw M3×8 CSK HD	2
16	RDC4066	Screw M5×12 Button Head	1
17	RDD4084	Chain	1
18	RDD4085	Screw M8×22 CSK HD	6
19	RDE4095	Slide	1
20	RDD4087	Screw M6×22 CAP HD	1
21	RDD4088	Guide bar	2
22	RDC4059	Screw M5×16 CAP HD	10
23	RDC4056	Grub Screw M6×15	5
24	RDC4057	M6 nut	5
25	RDD4092	Bush	2
26	RDD4093	Capstan Washer	2
27	RDD4094	Circlip	2
28	RDE4104	Right side panel	1
29	RDC4068	Screw M4×16 CSK HD	2
30	RDA4005	Cable bush	1
31	RDD4097	Main housing	1
32	RDC4055	Screw M8×25 CAP HD	2
33	RD4079	Spring washer	4
34	RDE4109	Magnet-230V	1
	RDE4110	Magnet-110V	1

Item#	Rotabroach P/N	Description	Qty/pcs
35	RDA4071	Screw M4×22	2
36	RDA4070	Cable clamp	1
37	RD4068	M4 nut	4
38	RD4069	M4 Washer	1
39	RD45604	Earth label	1
40	RDE4112	Left side panel	1
41	RDD4104	Capstan arm	3
42	RDD4105	Capstan Hub	1
43	RDD4106	Intermediate gear shaft	1
44	RDD4107	Screw M5×8 CAP HD	2
45	RDD4108	Handle insert	1
46	RDD4315	Screw M4×8 CSK HD	4
47	RDC4073	Screw M8×45 CAP HD	2
48	RDC4074	Power cable-230V	1
	RDD4112	Power cable-110V	1
49	RDD4113	Screw M6×15 Button Head	2
50	RDD4114	Capstan bracket	2
51	RDD4115	Bracket screw	2
52	RDD4116	Washer 6	2
53	RDD4117	Handle	1
54	RDD4118	Screw M4×12 Button Head	2
55	RDE4128	Control panel assembly-230V	1
	RDE4129	Control panel assembly-110V	1
56	RDD4123	Coolant bottle assembly	1
57	RDC4081	Clamp (using 110V)	1
58	RDC4080	Tapping screw ST2.9×12(using 110V)	3
59	RDD4126	Chuck	1
60	CA130	Arbor assembly	1
61	RDA3105	Safety glasses	1
62	RDD4128	Arbor shank	1
63	RDD4129	Drift	1
64	RDC4083	Safety belt	1
65	RD4152	3mm hexagonal spanner	1
66	RDC4082	stationary ring	2
67	RDD4132-230V	Spare brush	1pair
	RDD4133-110V		
68	RA3122	Pilot Pin	1
69	RDD4148	Foam insert	2

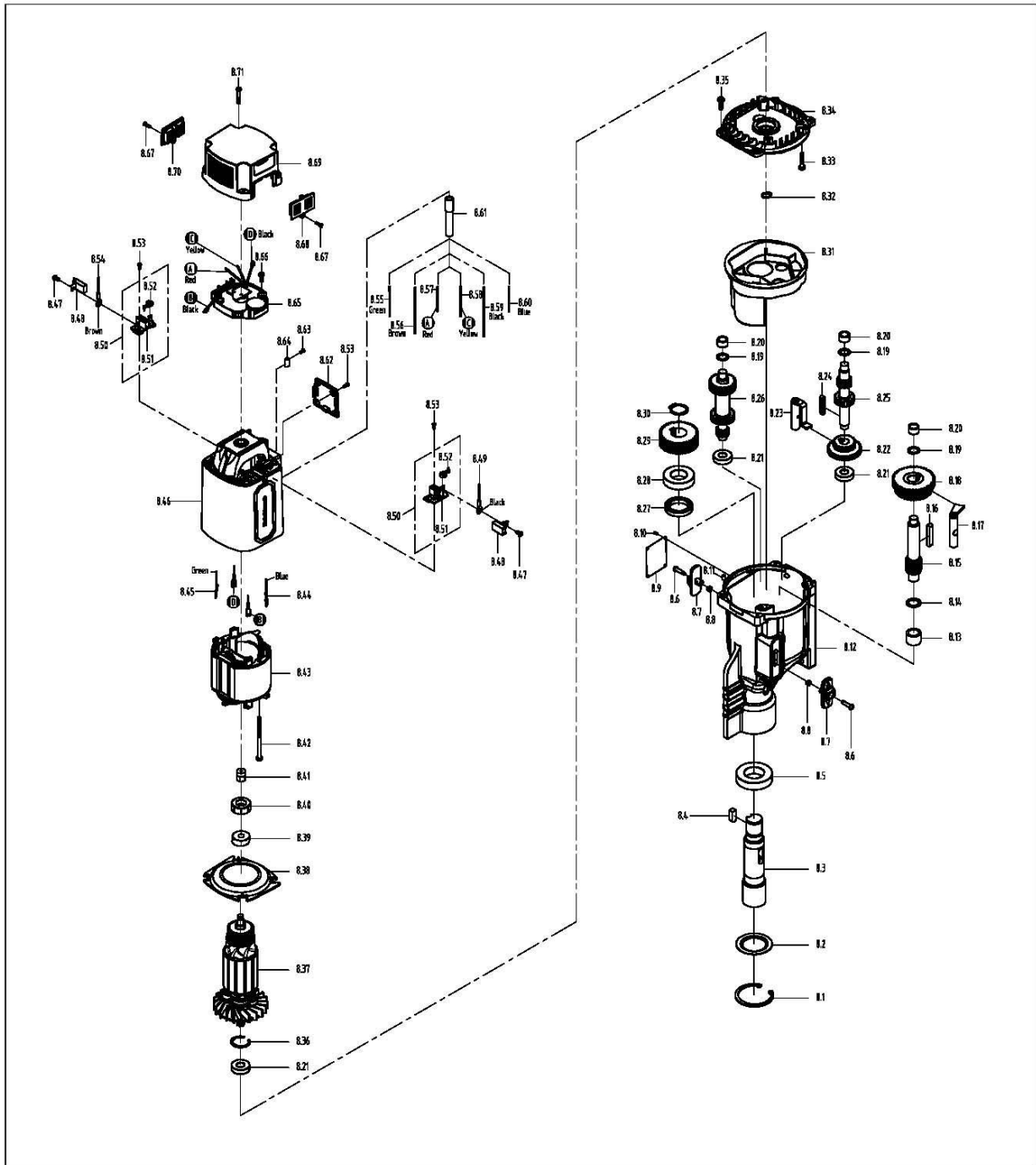
**17) EXPLODED VIEW OF MOTOR AND GEARBOX**



**PARTS LIST**

Item#	Rotabroach P/N	Description	Qty/pcs
8	RDE4023	Motor assembly-230V	1
	RDE4024	Motor assembly-110V	1
8.1	RDD4020	Circlip	1
8.2	RDD4021	Oil seal washer	1
8.3	RDD4022	Arbor spindle	1
8.4	RDD4023	Key steel	1
8.5	RDD4024	Rolling bearing 6006	1
8.6	RDC4013	Gear lever M4 shoulder bolt	2
8.7	RDB3030	Gear lever	2
8.8	RDB4008	Spring	2
8.9	RDE4032	Label	1
8.10	RDE4033	Rivet	4
8.11	RD45614	Straight Pin	1
8.12	RDE4034	Gear box	1
8.13	RDE4035	Needle bearing	1
8.14	RDE4036	Washer	1
8.15	RDE4037	Gear axel	1
8.16	RDE4038	Key steel	1
8.17	RDE4039	Right Gear lever shaft	1
8.18	RDE4040	Dual gear	1
8.19	RDE4041	Washer	3
8.20	RDE4042	Needle bearing	3
8.21	RD45522	Rolling bearing 6001	3
8.22	RDE4043	Dual gear	1
8.23	RDE4044	Left Gear lever shaft	1
8.24	RDE4045	Key steel	1
8.25	RDE4046	Gear axel	1
8.26	RDE4047	Gear assembly	1
8.27	RDD4037	Oil seal	1
8.28	RDD4038	Rolling bearing 6005	1
8.29	RDE4050	Drive gear	1
8.30	RDA4004	Circlip	1
8.31	RDE4051	Oil baffle plate	1
8.32	RDD4042	Circlip	1
8.33	RDD4051	Tapping screw ST4.8×25	4
8.34	RDE4053	Gear plate	1
8.35	RDD4050	Screw M5×16 Button Head	4
8.36	RDD4044	Circlip	1
8.37	RDE4056	Armature-230V	1
	RDE4057	Armature-110V	1
8.38	RDD4052	Baffle plate	1
8.39	RD43603	Rolling bearing 629	1
8.40	RDD4048	Bearing Sleeve	1

Item#	Rotabroach P/N	Description	Qty/pcs
8.41	RD35639	Inductor	1
8.42	RDE4062	Tapping screw ST4.8×75	2
8.43	RDE4063	Field coil-230V	1
	RDE4064	Field coil-110V	1
8.44	RDD4056	Lead wire	1
8.45	RDD4057	Lead wire	1
8.46	RDD4058	Motor housing	1
8.47	RDA4021	Screw M4×8 Button Head	2
8.48	RDD4059	Brush-230V	2
	RDD4060	Brush-110V	2
8.49	RDD4061	Lead wire	1
8.50	RDD4064	Brush frame unit	2
8.51	RDD4062	Brush frame assembly	2
8.52	RDD4063	Spring	2
8.53	RDA4034	Tapping screw ST2.9×8	8
8.54	RDD4065	Lead wire	1
8.55	RDD4066	Lead wire ( Green )	1
8.56	RDD4067	Lead wire ( Brown )	1
8.57	RDD4070	Lead wire ( Red )	1
8.58	RDE4069	Lead wire ( Yellow )	1
8.59	RDD4068	Lead wire ( Black )	1
8.60	RDD4069	Lead wire ( Blue )	1
8.61	RDD4072	Plastic tube	1
8.62	RDC4045	Wire box cover	1
8.63	RD45613	Screw M3×6	12
8.64	RD35617	Terminal	6
8.65	RDE4083	Speed controller module-230V	1
	RDE4084	Speed controller module-110V	1
8.66	RDA4035	Tapping screw ST4.2×12	2
8.67	RDD4076	Tapping screw ST2.9×12	2
8.68	RDD4077	Left brush cap	1
8.69	RDD4078	Top Cap	1
8.70	RDD4079	Right brush cap	1
8.71	RDD4080	Tapping screw ST4.2×25	4

**18)CONTROL PANEL AND PARTS LIST**

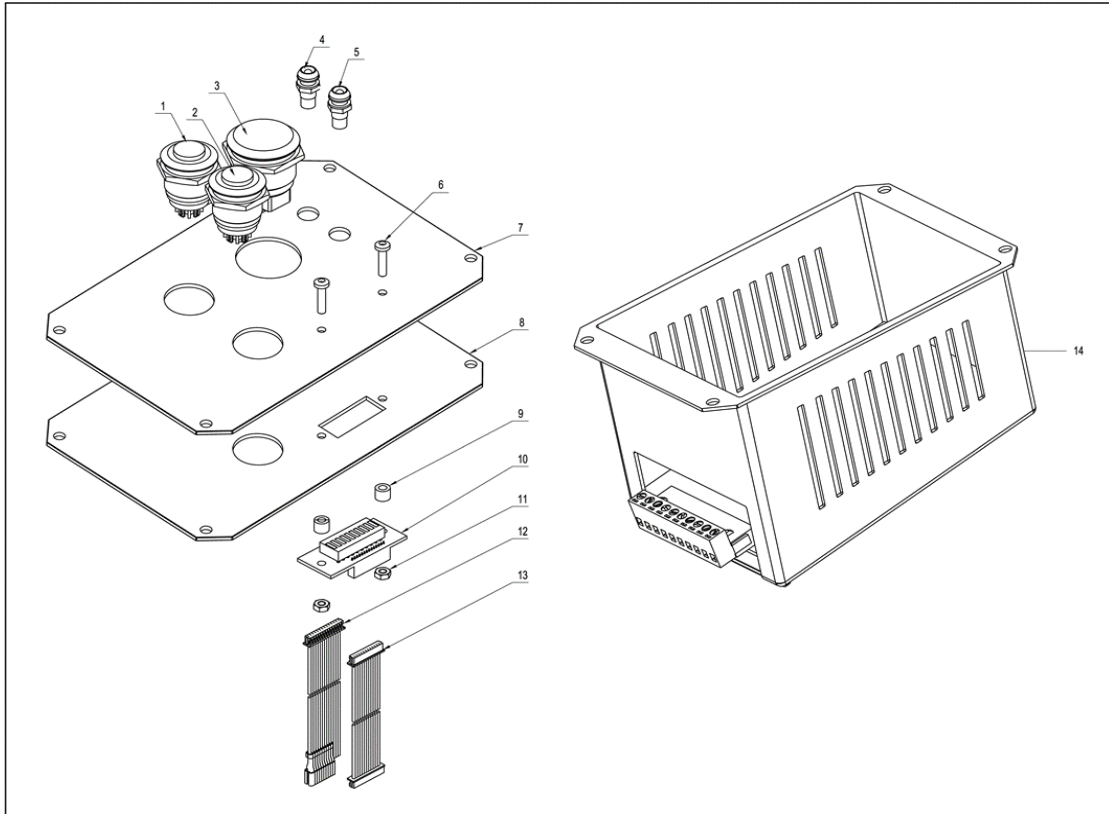

Item#	Rotabroach P/N	Description	Qty/pcs
1	RDA4051	Green Motor Switch	1
2	RDC4090	Blue Motor Switch	1
3	RDC4091	Magnet Switch	1
4	RDC4092	Red LED	1
5	RDC4093	Green LED	1
6	RDA4036	Screw M3×12 BTTN HD	2
7	RDD4005	Control Panel Cover	1
8	RDE4009	Control Plate-230V	1
	RDE4010	Control Plate-110V	1
9	RDA4019	Nylon Spacer	2
10	RDC4099	Array Board	1
11	RDA4205	M3 Nut	2
12	RDC4100	Connection line	1
13	RDC4101	Connection line	1
14	RDE4143/3	E100 PCBA-230V	1
	RDE4143/1	E100 PCBA-110V	1

**19) PIPE ADAPTOR KIT RD2311***FITTING INSTRUCTIONS*

- Dependent upon the size of the pipe to be cut (see illustrations) attach adjustable angle plates RD3328 with cap screws RD4325 and washers RD4205 (4 off each) to the magnet sides. Do not tighten.
- Locate the machine on the centreline of the pipe taking care that the magnet is in line with the longitudinal axis of the pipe.
- Switch on the magnet and move the sliding plates down to the outside diameter of the pipe. Tighten the screws on both sides by hand then check once again that the full length of the moving plates is touching the pipe at the front and back, fasten the plate securely. Feed the safety strap through the lugs at the front of the housing, around the pipe and pull tight.
- When cutting the hole DO NOT use excessive pressure but rather let the cutter ease into the cutting surface.

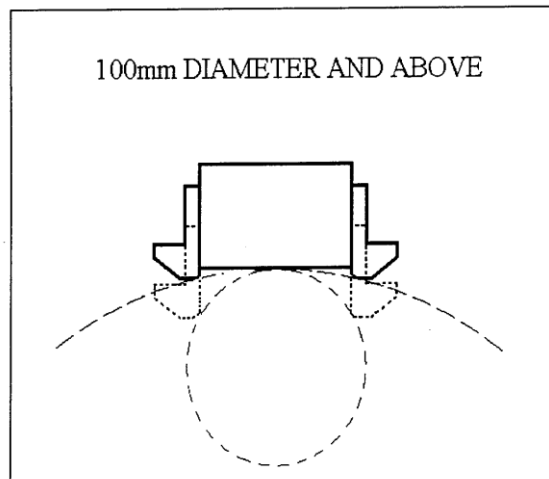
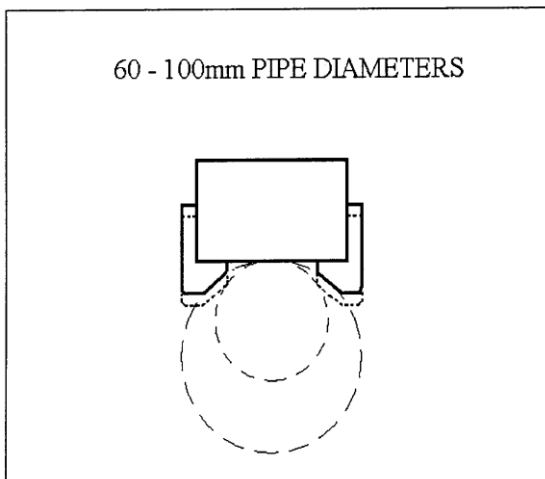

## 20) FITTING THE CHUCK

- The machine comes supplied with an RDD4128 (Arbor Shank) & RDD4126 (16mm Chuck).
- Insert RDD4128 into RDD4022 (Arbor Spindle), ensure a good and tight fit is achieved.
- Insert RDD4126 into RDD4128, ensure a good and tight fit is achieved.
- Replacing the chuck is the reverse sequence, by utilising RDD4129 (Drift).

## 21) MAINTENANCE

In order to 'get the best life' out of your Rotabroach machine always keep it in good working order.

A number of items must always be checked on Rotabroach machines.

Always before starting any job make sure the machine is in good working order and that there are no damaged or loose parts. Any loose parts must be tightened.

**Before proceeding with any maintenance work be certain that the power supply is disconnected.**

Description	Every operation	1 week	1 Month
Visual check of machine for damage	X		
Operation of machine	X		
Check brush wear		X	
Check magnetic base	X		
Check alignment of the machine			X
Check grease			X
Check armature			X

### Visually check the machine for damage.

The machine must be checked before operation for any signs of damage that will affect the operation of the machine. Particular notice must be taken to the mains cable, if the machine appears to be damaged it should not be used, failure to do so may cause injury or death.

### Check operation of the machine.

The machines operation must be checked to ensure that all components are working correctly.

### Machine Brushes

Should be checked to make sure there is no abnormal wear present (this should be checked at least once a week if used frequently). If the brush has worn more than 2/3 of the original length, the brushes should be changed. Failure to do so may cause damage to the machine.



**Magnetic base**

Before every operation the magnetic base should be checked to make sure that the base is flat and there is no damage present. An uneven magnet base will cause the magnet not to hold as efficiently and may cause injury to the operator.

**Adjustment of slide and bearing bracket alignment.**

An essential requirement of the machine is that the slide can move in a smooth and controlled manner, free of lateral movement and vibration.

This situation can be maintained by periodic adjustment of the slide and is accomplished in the following manner:

1. Place the machine in an upright position and, by means of the capstan, raise the slide to its highest position. Clean the brass gib strips and apply a small amount of light machine oil to the wear surfaces.
2. Now lower the slide back to its lowest position. Bring the slide into the center of the dovetail slide housing and loosen screws thus allowing free movement of the arbor support bracket.
3. Commencing with the middle screws, gently feed in all the screws until slight resistance is encountered.
4. Operate the slide up and down a few times to test the movement and make any further necessary adjustments. Try to ensure that all the screws are exerting a uniform pressure on the slide from top to bottom. A perfectly adjusted slide will operate freely up and down without any sideways movement.
5. Now raise the slide to its highest position. Slightly undo the arbor bearing bracket and, using fingers only, tighten the screws.
6. Place the machine on a steel plate, connect to power supply and switch on the magnet. Start up the motor. If the arbor is incorrectly aligned, the arbor support bracket will be seen to oscillate. Make any necessary further adjustments to the bracket to ensure correct alignment of the spindle and finally tighten the screws using a spanner. Lastly tighten the arbor bearing bracket.

**Check machines grease.**

The gearbox grease should be checked once a month to ensure all moving components are covered to prevent wear. The grease should be changed at least once a year to ensure you gain the best from your machine.

**Check Armature of the machine.**

This should be checked at least once a month to check that there are no visual signs of damage to the body or to the commutator. Some signs of wear will be seen on the commutator over a period of time but this is normal (this is the part that comes into contact with the brushes) however, if there are any signs of abnormal damage the part should be replaced.

## 22) TROUBLE SHOOTING

Magnet and motor do not function	<ul style="list-style-type: none"> <li>- The magnet switch is not connected to the power supply</li> <li>- Damaged or defective wiring</li> <li>- Defective fuse</li> <li>- Defective magnet switch</li> <li>- Defective control unit</li> <li>- Defective power supply</li> </ul>
Magnet does function, the motor does not	<ul style="list-style-type: none"> <li>- Damaged or defective wiring</li> <li>- Carbon brushes are stuck or worn out</li> <li>- Defective magnet switch</li> <li>- Defective on / off switch</li> <li>- Defective control unit</li> <li>- Defective armature and/or field</li> <li>- Defective protective reed switch</li> </ul>
Magnet does not function, the motor does	<ul style="list-style-type: none"> <li>- Defective magnet</li> <li>- Defective fuse</li> <li>- Defective control unit</li> </ul>
Hole cutters break quickly, holes are bigger than the hole cutter	<ul style="list-style-type: none"> <li>- Play in the guide</li> <li>- Bent spindle</li> <li>- Shaft extending from the motor is bent</li> <li>- Pilot bent</li> </ul>
Motor running roughly and/or seizing up	<ul style="list-style-type: none"> <li>- Bent spindle</li> <li>- Shaft extending from the motor is bent</li> <li>- Triangular guide not mounted straight</li> <li>- Dirt between spindle and triangular guide</li> </ul>
Motor making a rattling sound	<ul style="list-style-type: none"> <li>- Gear ring (bottom of the armature) worn out</li> <li>- Gear(s) worn out</li> <li>- No grease in gear box</li> </ul>
Motor humming, big sparks and motor has no force	<ul style="list-style-type: none"> <li>- Armature damaged</li> <li>- Field burned</li> <li>- Carbon brushes worn out</li> </ul>
Motor does not start or fails.	<ul style="list-style-type: none"> <li>- Damaged or defective wiring</li> <li>- Damage to armature or field coil</li> <li>- Damaged or defective brushes</li> </ul>
Guiding takes a great deal of effort	<ul style="list-style-type: none"> <li>- Guide is set too tight</li> <li>- Guide is dry</li> <li>- Guide/gear- rack/rotation system is dirty or damaged</li> </ul>
Insufficient magnetic force	<ul style="list-style-type: none"> <li>- Damaged or defective wiring</li> <li>- Bottom of magnet not clean and dry</li> <li>- Bottom of magnet not flat</li> <li>- Work piece is not bare metal</li> <li>- Work piece is not flat</li> <li>- Work piece is too thin less than 10mm</li> <li>- Defective control unit</li> <li>- Defective magnet</li> </ul>
Frame under voltage	<ul style="list-style-type: none"> <li>- Damaged / defective wiring</li> <li>- Defective magnet</li> <li>- Motor seriously dirty</li> </ul>
Fuse blows when magnet switch is turned on	<ul style="list-style-type: none"> <li>- Damaged or defective wiring</li> <li>- Wrong value fuse</li> <li>- Defective magnet switch</li> <li>- Defective control unit</li> <li>- Defective magnet</li> </ul>
Fuse blows when motor is started up	<ul style="list-style-type: none"> <li>- Damaged or defective wiring</li> <li>- Wrong value fuse</li> <li>- Motor running roughly</li> <li>- Defective armature and / or field</li> <li>- Carbon brushes worn out</li> <li>- Defective control unit</li> </ul>
Rotation system free stroke too long	<ul style="list-style-type: none"> <li>- Loose or defective gear-rack</li> <li>- Defective rotation system</li> </ul>

## 23) CUTTER SELECTION AND SPEEDS

Material	Material Hardness	Cutter
Mild and free cutting steels	<900N/mm <sup>2</sup>	RAP or RAPL
Mild and free cutting steels	<900N/mm <sup>2</sup>	SRCV or SRCVL
Steel angle and joists	<900N/mm <sup>2</sup>	RAP or RAPL
Steel angle and joists	<900N/mm <sup>2</sup>	SRCV or SRCVL
Plate and sheet steel	<900N/mm <sup>2</sup>	RAP or RAPL
Plate and sheet steel	<900N/mm <sup>2</sup>	SRCV or SRCVL
Aluminium	<900Nmm <sup>2</sup>	RAP or RAPL
Aluminium	<900N/mm <sup>2</sup>	SRCV or SRCVL
Brass	<900N/mm <sup>2</sup>	RAP or RAPL
Brass	<900N/mm <sup>2</sup>	SRCV or SRCVL
Cast iron	<900N/mm <sup>2</sup>	RAP or RAPL
Cast iron	<900N/mm <sup>2</sup>	SRCV or SRCVL
Stainless steel	<900N/mm <sup>2</sup>	RAP or RAPL
Stainless steel	<900N/mm <sup>2</sup>	SRCV or SRCVL
Stainless steel	>1400N/mm <sup>2</sup>	CWC to CWCX
Rail track	>1400N/mm <sup>2</sup>	SCRWC or SCRWCL
Tool steel	>1400N/mm <sup>2</sup>	CWC to CWCX
Die Steel	>1400N/mm <sup>2</sup>	CWC to CWCX
Cast Iron	>1800N/mm <sup>2</sup>	CTCT
Inox	>1800N/mm <sup>2</sup>	CTCT
Inconel	>1800N/mm <sup>2</sup>	CTCT
Fine Grain Steel	>1800N/mm <sup>2</sup>	CTCT
Hardox	>1800N/mm <sup>2</sup>	CTCT

The data listed below is for reference purposes only, and indicate potential starting conditions. It is the responsibility of the site operation manager to determine correct application requirements.

Material to be cut	Cutting surface speed Meters/min	Cutter diameter/Material/RPM relationship													
		13		14		18		22		30		50		65	
Lower - Upper		L	U	L	U	L	U	L	U	L	U	L	U	L	U
Aluminium	60 - 90	1469	2203	1364	2046	1061	1591	868	1302	637	955	382	573	294	441
Brass & Bronze	40 - 50	979	1224	909	1137	707	884	579	723	424	530	255	318	196	245
Iron: cast(soft)	30 - 50	734	1224	682	1137	530	884	434	723	318	530	191	318	147	245
cast(hard)	15 - 21	367	514	341	477	265	371	217	304	159	223	95	134	73	103
cast(malleable)	15 - 30	367	734	341	682	265	530	217	434	159	318	95	191	73	147
Steel: mild	24 - 30	588	734	546	682	424	530	347	434	255	318	153	191	118	147
high tensile	3 - 5	73	122	68	114	53	88	43	72	32	53	19	32	15	24
stainless (free cutting)	15 - 18	367	441	341	409	265	318	217	260	159	191	95	115	73	88
stainless (heat resisting)	6 - 13	26	318	136	296	106	230	87	188	64	138	38	83	29	64

These are only starting points. They will vary with application and work piece condition.

Material or Application Type	Feed Per Tooth (mm)
Thin Walled Workpieces Oblique Entry / Curved Surfaces Semi-Circles / Fragile Setups	.0254 / .0508 (.0762 FPT with Work Hardening Materials)
Soft / Gummy Materials	.1016 / .127
Typical / Average Applications	.0762 / .1016
Deep Holes	.1016 / .127

Difficult-to-machine materials will require reduced feed rates.

# Rotabroach™

## 24) WARRANTY AND CE STATEMENTS

Rotabroach™ warrants its machines to be free from faulty parts, under normal usage of machines, for a period of 12 months from initial date of purchase. All other parts (excluding cutters) are under warranty for 90 days, provided that the warranty registration card (or online registration) has been completed and returned to Rotabroach™ or its designated distributor within a period of (30) days from the purchase date. Failure to do so will void the warranty. If the stated is adhered to, Rotabroach™ will repair or replace (at its option) without charge any faulty items returned.

### **This Warranty does not cover:**

1. Components that are subject to natural wear and tear caused by the use is not in accordance with the operator's instructions
2. Defects in the tool caused by non-compliance with the operating instructions, improper use, abnormal environment conditions, inappropriate operating conditions overload or insufficient servicing or maintenance.
3. Defects caused by using accessories, components or spare parts other than original Rotabroach™ parts.
4. Tools to which changes or additions have been made.
5. Electrical components are subject to manufacturer's warranty.

Your online registration can be submitted at [www.rotabroach.co.uk](http://www.rotabroach.co.uk)

The warranty claim must be logged within the warranty period. This requires the submission or sending of the **complete** tool in question with the original sales receipt which must indicate the purchase date of the product. A complaint form must also be submitted prior to the return.

This can be found online at [www.rotabroach.co.uk](http://www.rotabroach.co.uk). Failure to complete this form will result in the delay of your claim.

All goods returned defective must be returned pre-paid to Rotabroach™, in no event shall Rotabroach™ be liable for subsequent direct, or indirect loss or damage.

THIS WARRANTY IS IN LIEU OF ANY OTHER WARRANTY, (EXPRESSED OR IMPLIED) INCLUDING ANY WARRANTY OF MERCHANTABILITY OR FITNESS FOR A PARTICULAR PURPOSE. ROTABROACH™ RESERVE THE RIGHT TO MAKE IMPROVEMENTS AND MODIFICATIONS TO DESIGN WITHOUT PRIOR NOTICE

**Known and Trusted Worldwide for Quality, Performance and Reliability**

**EC Declaration of Conformity**

Based on the referenced test reports, the below product has been found to comply with the relevant harmonised standard(s) to the directive(s) listed on this verification at the time the tests were carried out.

Name and address of manufacturer: Rotabroach Ltd  
Burgess Road, Sheffield Road, Sheffield  
S9 3WD, United Kingdom

Product tested: ELEMENT 100/1S  
ELEMENT 100/3

Application of product: Hole drilling metal

Relevant standards/directives EN12717 : 2001+A1 : 2009  
The EMC Directive 2014/30/EU  
The Machinery Directive 2006/42/EC – Annex I  
EN 62841-1:2015  
EN55014-1:2017  
EN55014-2:2015  
EN61000-3-2:2014  
EN61000-3-3:2013

Name and Address of  
Responsible person.

Mr Mathew Grey  
Managing Director  
Burgess Road,  
Sheffield  
S9 3WD  
United Kingdom

Date:

28th July 2020

Signature:

A handwritten signature in black ink, appearing to read 'Mathew Grey', is written over a horizontal line.