

RotabroachTM

ELEMENT 14

METAL CUTTING SAW

Model Number Element 14/1, Element 14/3

This machine (Serial Number) is CE approved.

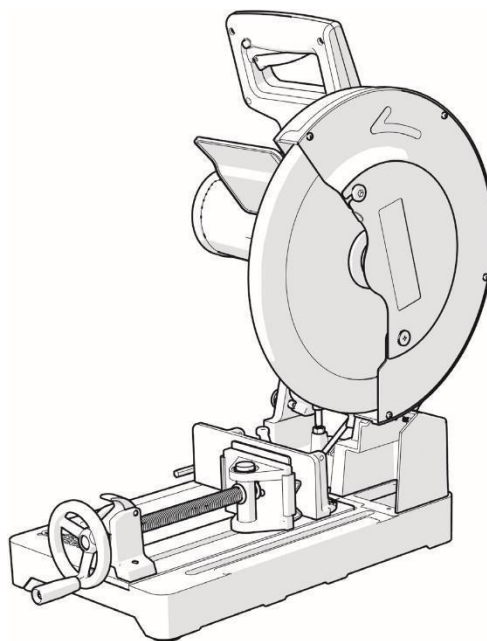

Rotabroach[®]

**Rotabroach Ltd
Burgess Road
Sheffield, South Yorkshire
United Kingdom
S9 3WD**

Tel: +44 (0) 114 2212 510
Email: info@rotabroach.co.uk

Fax: +44 (0) 114 2212 563
Website: www.rotabroach.co.uk

**Thank you for purchasing our Element 14 Chop saw.
We would really like your feedback on this machine.**

Other Products by Rotabroach:



Thank you for your purchase

CONTENTS OF THE MANUAL 

	Page
1) Intended use	4
2) General safety rules	4
3) Additional Safety Instructions	6
4) Information plate symbols	8
5) Unpacking	8
6) Specification	9
7) Operating instructions	10
8) Extension cable selection	14
9) Maintenance	15
10) Machine breakdown	16
11) Parts list	17
12) Trouble shooting	18
13) Warranty statement	19

1) INTENDED USE

WARNING: This product is a Hand Operated Chop Saw and has been designed to be used with special Rotabroach blades. Only use accessories designed for use in this machine and/or those recommended specifically by Rotabroach Power Tools Ltd. When fitted with an appropriate blade this machine can be used to cut:

Mild Steel

Aluminium

Wood

302, 303 & 304 Grade Stainless Steel

Note: Cutting galvanised steel may reduce blade life.

WARNING: This product is a Hand Operated Chop Saw and must only be used as such. It must not be modified in anyway or used to power any other equipment or drive any other accessories other than those mentioned in this Instruction Manual.

WARNING: This machine is not intended for use by persons (including children) with reduced physical, sensory or mental capabilities, or lack of experience and knowledge, unless they have been given supervision or instruction concerning the safe use of the machine by a person responsible for their safety and who is competent in its safe use. Children should be supervised to ensure that they do not have access to, and are not allowed to play with, this machine

2) GENERAL SAFETY RULES

Please read these operating and safety instructions carefully and completely. For your own safety, if you are uncertain about any aspect of using this equipment please access the relevant technical helpline, the number of which can be found on the Rotabroach website.

ELECTRICAL SAFETY: This machine is fitted with the correct moulded plug and mains lead for its designated use.

If the power cord is damaged, it must be replaced by an approved cord or assembly available from the manufacturers or its service agent.

OUTDOOR USE: WARNING: For your protection if this tool is to be used outdoors it should not be exposed to rain, or used in damp locations. Do not place the tool on damp surfaces. Use a clean, dry workbench if available. For added protection use a residual current device (R.C.D.) that will interrupt the supply if the leakage current to earth exceeds 30mA for 30ms. Always check the operation of the residual current device (R.C.D.) before using the machine.

If an extension cable is required it must be a suitable type for use outdoors and so labelled. The manufacturer's instructions should be followed when using an extension cable.

POWER TOOL GENERAL SAFETY INSTRUCTIONS

(These General Power Tool Safety Instructions are as specified in BS EN 60745-1:2009 & EN 61029-1:2009).

WARNING: Read all safety warnings and instructions. Failure to follow the warnings and instructions may result in electric shock, fire and/ or serious injury. Save all warnings and instructions for future reference. The term "power tool" in the warnings refers to your mains-operated (corded) power tool or battery-operated cordless power tool.

General Power Tool Safety Warnings (Work area safety)

- Keep work area clean and well lit. Cluttered or dark areas invite accidents.
- Do not operate power tools in explosive atmospheres, such as in the presence of flammable liquids, gases or dust. Power tools create sparks which may ignite the dust or fumes.
- Keep children and bystanders away while operating power tool. Distractions can cause you to lose control.

General Power Tool Safety Warnings [Electrical Safety]

- Power tool plugs must match the outlet. Never modify the plug in any way. Do not use any adapter plugs

with earthed (grounded) power tools. Unmodified plugs and matching outlets will reduce the risk of electric shock.

b) Avoid body contact with earthed or grounded surfaces, such as pipes, radiators, ranges and refrigerators. There is an increased risk of electric shock if your body is earthed or grounded.

c) Do not expose power tools to rain or wet conditions. Water entering a power tool will increase the risk of electric shock.

d) Do not abuse the cord. Never use the cord for carrying, pulling or unplugging the power tool. Keep cord away from heat, oil, sharp edges or moving parts. Damaged or entangled cords increase the risk of electric shock.

e) When operating a power tool outdoors, use an extension cord suitable for outdoor use. Use of a cord suitable for outdoor use reduces the risk of electric shock.

f) If operating a power tool in a damp location is unavoidable, use a residual current device (RCD) protected supply. Use of an RCD reduces the risk of electric shock.

General Power Tool Safety Warnings [Personal Safety].

a) Stay alert, watch what you are doing and use common sense when operating a power tool. Do not use a power tool while you are tired or under the influence of drugs, alcohol or medication. A moment of inattention while operating power tools may result in serious personal injury.

b) Use personal protective equipment. Always wear eye protection. Protective equipment such as dust masks, non-skid safety shoes, hard hat or hearing protection used for appropriate conditions will reduce personal injuries.

c) Prevent unintentional starting. Ensure the switch is in the off position before connecting to power source and or battery pack, picking up or carrying the tool. Carrying power tools with your finger on the switch or energising the power tools that have the switch on invites accidents.

d) Remove any adjusting key or wrench before turning the power tool on. A wrench or key left attached to a rotating part of a power tool may result in personal injury.

e) Do not overreach. Always keep proper footing and balance. This enables better control of the power tool in unexpected situations.

f) Dress properly. Do not wear loose clothing or jewellery. Keep your hair, clothing and gloves away from moving parts. Loose clothes, jewellery or long hair can be caught in moving parts.

g) If devices are provided for the connection of dust extraction and collection facilities, ensure that these are connected and properly used. Use of dust collection can reduce dust-related hazards

General Power Tool Safety Warnings [Power tool use and care].

a) Do not force the power tool. Use the correct power tool for your application. The correct power tool will do the job better and safer at a rate for which it was designed.

b) Do not use the power tool if the switch does not turn it on or off. Any power tool that cannot be controlled with the switch is dangerous and must be repaired.

c) Disconnect the power tool from the power source and/or battery pack from the power tool before making any adjustments, changing accessories, or storing power tools. Such preventative safety measures reduce the risk of starting the power tool accidentally.

d) Store idle power tools out of the reach of children and do not allow persons unfamiliar with the power tool or these Instructions to operate the power tool. Power tools are dangerous in the hands of untrained users.

e) Maintain power tools. Check for misalignment or binding of moving parts, breakage of moving parts and any other condition that may affect the power tools operation. If damaged, have the power tool repaired before use. Many accidents are caused by poorly maintained power tools.

f) Keep cutting tools sharp and clean. Properly maintained cutting tools with sharp cutting edges are less likely to bind and are easier to control.

g) Use the power tool, accessories and tool bits etc. in accordance with these instructions, considering

the working conditions and the work to be performed. Use of the power tool for operations different from those intended could result in a hazardous situation.

General Power Tool Safety Warnings [Service]

a) Have your power tool serviced by a qualified repair person using only identical replacement parts. This will ensure that the safety of the power tool is maintained.

HEALTH ADVICE:

WARNING: When using this machine, dust particles may be produced. In some instances, depending on the materials you are working with, this dust can be particularly harmful. If you suspect that paint on the surface of material you wish to cut contains lead, seek professional advice. Lead based paints should only be removed by a professional and you should not attempt to remove it yourself. Once the dust has been deposited on surfaces, hand to mouth contact can result in the ingestion of lead. Exposure to even low levels of lead can cause irreversible brain and nervous system damage. The young and unborn children are particularly vulnerable. You are advised to consider the risks associated with the materials you are working with and to reduce the risk of exposure. As some materials can produce dust that may be hazardous to your health, we recommend the use of an approved face mask with replaceable filters when using this machine.

You should always:

- Work in a well-ventilated area.
- Work with approved safety equipment, such as dust masks that are specially designed to filter microscopic particles.

WARNING: The operation of any power tool can result in foreign objects being thrown towards your eyes, which could result in severe eye damage. Before beginning power tool operation, always wear safety goggles or safety glasses with side shield or a full-face shield where necessary.

3) ADDITIONAL SAFETY INSTRUCTIONS

- DANGER:** Keep hands away from cutting area and the blade. Keep your second hand on auxiliary handle, or motor housing. If both hands are holding the saw, they cannot be cut by the blade.
- Do not reach underneath the workpiece. The guard cannot protect you from the blade below the workpiece.
- Adjust the cutting depth to the thickness of the workpiece. Less than a full tooth of the blade teeth should be visible below the workpiece.
- Never hold piece being cut in your hands or across your leg. Secure the workpiece to a stable platform. It is important to support the work properly to minimize body exposure, blade binding, or loss of control.
- Hold power tool by insulated gripping surfaces when performing an operation where the cutting tool may contact hidden wiring or its own cord. Contact with a "live" wire will also make exposed metal parts of the power tool "live" and shock the operator.
- When ripping always use a rip fence or straight edge guide. This improves the accuracy of cut and reduces the chance of blade binding.
- Always use blades with correct size and shape (diamond versus round) of arbor holes. Blades that do not match the mounting hardware of the saw will run eccentrically, causing loss of control.
- Never use damaged or incorrect blade washers or bolt. The blade washers and bolt were specially designed for your saw, for optimum performance and safety of operation.
- Do not use High Speed Steel (HSS) saw blades.
- Inspect the machine and the blade before each use. Do not use deformed, cracked, worn or otherwise damaged blades.
- Never use the saw without the original guard protection system. Do not lock the moving guard in the open position. Ensure that the guard operates freely without jamming.

l) Only use blades that comply with the characteristics specified in this manual. Before using accessories, always compare the maximum allowed RPM of the accessory with the RPM of the machine.

Causes and operator prevention of kickback:

Kickback is a sudden reaction to a pinched, bound or misaligned saw blade, causing an uncontrolled saw to lift up and out of the workpiece toward the operator:

1. When the blade is pinched or bound tightly by the kerf closing down, the blade stalls and the motor reaction drives the unit rapidly back toward the operator.
2. If the blade becomes twisted or misaligned in the cut, the teeth at the back edge of the blade can dig into the top surface of the workpiece causing the blade to climb out of the kerf and jump back towards the operator.

Kickback is the result of saw misuse and/ or incorrect operating procedures or conditions and can be avoided by taking proper precautions as given below.

- a) Maintain a firm grip with both hands on the saw and position your arms to resist kickback forces. Position your body to either side of the blade, but not in line with the blade. Kickback could cause the saw to jump backwards, but kickback forces can be controlled by the operator, if proper precautions are taken.
- b) If the blades are binding, or when interrupting a cut for any reason, release the trigger and hold the saw motionless in the material until the blades come to a complete stop. Never attempt to remove the saw from the work or pull the saw backward while the blades are in motion or kickback may occur. Investigate and take corrective actions to eliminate the cause of blade binding.
- c) When restarting a saw in the workpiece, centre the saw blade in the kerf and check that saw teeth are not engaged into the material. If saw blade is binding, it may walk up or kickback from the workpiece as the saw is restarted.
- d) Support large panels to minimise the risk of blade pinching and kickback. Large panels tend to sag under their own weight. Supports must be placed under the panel on both sides, near the line of cut and near the edge of the panel.
- e) Blade depth and bevel adjusting locking levers must be tight and secure before making a cut. If the blade adjustment shifts while cutting it may cause binding and kickback.
- f) Do not use dull or damaged blades. Unsharpened or improperly set blades produce a narrow kerf causing excessive friction, blade binding and kickback.
- g) Use extra caution when making a "plunge cut" into existing walls or other blind areas. The protruding blade may cut objects that can cause kickback.
- h) Check lower guard for proper closing before each use. Do not operate the saw if lower guard does not move freely and close instantly. Never clamp or tie the lower guard into the open position. If saw is accidentally dropped, lower guard may be bent. Raise the lower guard with the retracting handle (if equipped) and make sure, it moves freely and does not touch the blade or any other part, in all angles and depths of cut.
- i) Check the operation of the lower guard spring. If the guard and the spring are not operating properly, they must be serviced before use. Lower guard may operate sluggishly due to damaged parts, gummy deposits, or a build-up of debris.
- j) Lower guard may be retracted manually only for special cuts such as "plunge cuts" and "compound cuts." Raise lower guard by retracting handle and as soon as blade enters the material, the lower guard must be released. For all other sawing, the lower guard should operate automatically.
- k) Always observe that the lower guard is covering the blade before placing saw down on a bench or the floor. An unprotected, coasting blade will cause the saw to walk backwards, cutting whatever is in its path. Be aware of the time it takes for the blade to stop after switch is released.

WARNING: If any parts are missing, do not operate your machine until the missing parts are replaced. Failure to follow this rule could result in serious personal injury.

4) INFORMATION PLATE SYMBOLS



1. Refer to the user manual for operational and safety issues with regard to this machine.
2. Dispose of the machine and electrical components correctly.
3. Eye protection must be worn when operating the machine.
4. Ear defenders must be worn when operating the machine.

5) UNPACKING

Caution: This packaging contains sharp objects. Take care when unpacking. Remove the machine, together with the accessories supplied from the packaging. Check carefully to ensure that the machine is in good condition and account for all the accessories listed in this manual. Also make sure that all the accessories are complete. If any parts are found to be missing, the machine and its accessories should be returned together in their original packaging to the retailer. Do not throw the packaging away; keep it safe throughout the guarantee period. Dispose of the packaging in an environmentally responsible manner. Recycle if possible. Do not let children play with empty plastic bags due to the risk of suffocation.

6) SPECIFICATION

	110v	230v
Motor Rating	1800w	2200w
Voltage	110	230-240
Amperes	16	10
Hertz (Cycles)	50-60	50-60
Phase	Single	
RPM	1500	
Weight	28kgs	
Sound Pressure Level	108 dB(A)	
Sound Power Level	121 dB(A)	
Vibration Level	1.39 m/s ²	

Ear and eye defenders must be worn when operating this machine. Wear gloves to protect hands when operating the machine.

Suitable only for a single phase 50-60Hz A.C. power supply

DO NOT USE ON D.C. SUPPLY

WARNING: THIS APPLIANCE MUST BE EARTHED!

NB: ANY MODIFICATIONS TO THIS MACHINE WILL INVALIDATE THE GUARANTEE

7) OPERATING INSTRUCTIONS

GETTING STARTED – PREPARATION

RELEASING the CUTTING HEAD

The cutting head will automatically rise to the upper position once it is released from the locked down position.

To Release the cutting head from the Locked Down position: Gently press down on the cutting handle.

- Pull out the head latching pin and lock in the outer position

(Fig. 1) Allow the cutting head to rise to its upper position.

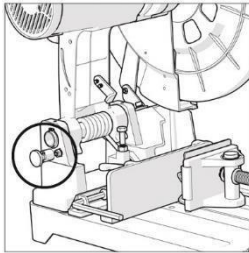

Fig.1

If Release is Difficult:

- Gently rock the cutting head up and down.
- Pull the latching pin fully out and turn 1/4 of a turn to lock in the outer position.

Note: We recommend that when the machine is not in use the cutting head is locked in its down position with the latching pin fully engaged in its socket.

INSTALLING or REMOVING a BLADE

WARNING: Only use genuine Rotabroach blades, or Rotabroach approved blades which are designed for this machine. Ensure that the maximum recommended blade speed of the blade is compatible with the machine.

WARNING: Only perform this operation with the machine disconnected from the power supply.

Note: It is recommended that the operator considers wearing protective gloves when handling the blade during installation or when changing the machine's blade.

Removing a Blade:

- Ensure that the cutting head is in its upper position.
- Loosen the fastener screw securing the arbor guard and rotate the guard upwards to reveal the machine's arbor. **(Fig. 2)**

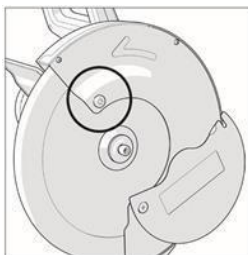

Fig.2

- Engage the arbor lock by pressing the arbor lock button.

(Fig. 3)

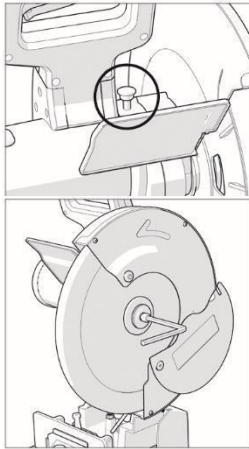

Fig.3

- Use the supplied hex key to loosen the arbor screw. (Fig. 4)

Fig.4

Note: The arbor screw has a right-hand thread. Turn clockwise to tighten. Turn counter clockwise to loosen.

- Remove the arbor screw, washer and outer blade flange and store safely for future installation.
- Retract the lower blade guard up into the upper blade guard by rotating it by hand. (Fig. 5)

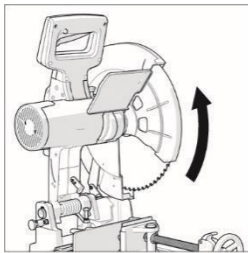

Fig.5

- Remove the blade, leaving the inner blade flange in its service position.

Installing a Blade:

- Ensure that all components are free from dirt and debris.
- Install the blade onto the inner blade flange and arbor, ensuring that the direction and rotation arrow on the blade matches the direction of arrow rotation found on the machine's upper blade guard. (Fig. 6)

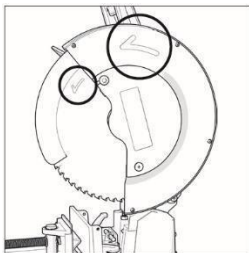

Fig 6.

- Reinstall the outer blade flange, washer and arbor screw.
- Lock the arbor by pressing the arbor lock button.
- Tighten the arbor screw using the 8mm hex key.
- Return the arbor guard to its service position and tighten the crosshead screw.
- Check that the arbor lock has been released by rotating the blade by hand.
- Ensure that the hex key is removed from the arbor screw and is safely stored for future use.
- Check the installation, and particularly the operation of the retractable lower blade guards by lowering and raising the cutting head a few times.

WARNING: After installing a new blade, always run the machine, without load, for a couple of minutes. Stand away from the blade. If the blade were to contain an undetected flaw, it could shatter during this trial run.

CUTTING HEAD TRAVEL

• Cutting Head Downward Travel Adjustment

To prevent the blade from contacting any part of the machine's metal base the downward travel of the cutting head can be adjusted. Lower the cutting head and check for any blade contact with the machine's base.

If the downward travel of the cutting head needs to be adjusted:

- Loosen the locknut on the downward travel stop screw. **(Fig. 7a)**

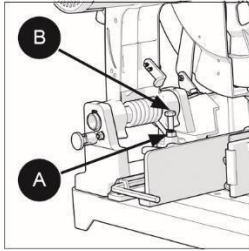

Fig.7

- Turn the adjusting screw **(Fig. 7b)** out (counter clockwise) to decrease the downwards travel of the cutting head.
- Turn the adjusting screw in (clockwise) to increase the downwards travel of the cutting head.
- Tighten the adjustment screw locknut when satisfactory downward travel of the cutting head is achieved.

CUTTING ANGLE ADJUSTMENT

Note: The rear vise jaw can be turned through 45°.

The rear vise jaw is factory set at 0° (at 90° to the blade) so that the blade cuts squarely across material positioned in the vise. For angled cuts, the rear vise jaw can be swung through (up to) 45°, with a protractor scale being included on the vise jaw for ease and accuracy of setting.

To angle the rear vise jaw:

- Loosen the M10 socket headed screw and the lever handled locking screw. **(Fig. 8)**

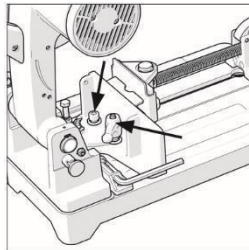

Fig.8

- Turn the rear vise jaw to the required angle.
- Tighten the socket headed screw securely using the supplied hex key and tighten the lever handled locking screw.

Note: The lever handle locking screw has a spring-loaded repositionable lever. Repositioning of the lever may be necessary to ensure that the locking screw can be tightened sufficiently when the rear vise jaw is angled. To reposition the lever on the screw, pull the lever upwards and rotate the lever to a convenient position (one that allows the screw to be tightened) release the lever and tighten the screw. The front vise jaw will automatically compensate for any set angle of the rear jaw, or to accommodate irregular shaped workpieces.

REPOSITIONING THE REAR VISE JAW

The rear vise jaw can be removed from the machine's base and repositioned. **(Fig.9)**

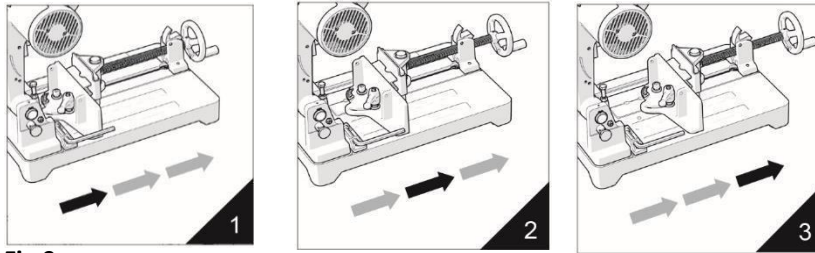

Fig.9

- Reposition the rear vise jaw; there are three (3) possible positions available because of the six (6) threaded holes in the machine's base. Replace lever handled locking screw and the socket headed screw into their new service positions. Ensure that all standard and locking washers are correctly positioned.

Repositioning the rear vise jaw to the rear-most position will enable wider pieces of material to be cut than is possible with the rear vise jaw in either of the more forward positions.

'V' Clamp Jaw (If supplied)

The 'V' Clamp Jaw slips over the moving front vise jaw. It should be used when cutting round material as it provides greater clamping security. It should also be used to cut square tube in a diamond position (**Fig. 10**).

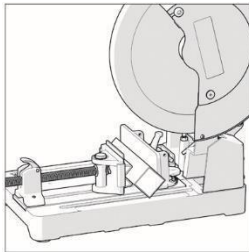

Fig.10

OPERATING INSTRUCTIONS

WARNING: The tool is recommended to always be supplied via a residual current device with a rated residual current of 30 mA or less.

PREPARING TO MAKE A CUT

Do not overreach. Keep good footing and balance. Stand to one side so that your face and body are out of line of a possible kickback.

Caution: The minimum cut off piece must be 8mm (5/16") or greater in length to avoid the piece falling through the blade slot and causing any potential danger. (**Fig 11**)

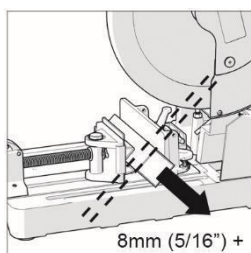

Fig.11

WARNING: Freehand cutting is a major cause of accidents and should not be attempted. Ensure that the workpiece is firmly secured in the vise.

- The machine's base should be clean and free from any swarf or sawdust etc. before the workpiece is clamped into position.
- Ensure that the 'cut-off' material is free to move sideways away from the blade when the cut is completed. Ensure that the 'cut-off' piece cannot become 'jammed' in any other part of the machine.
- Do not use this saw to cut small pieces. If the workpiece being cut would cause your hand or fingers to be within 150mm of the saw blade, the workpiece is too small. Angles should be clamped in an inverted position so that the point of the section is uppermost. (<5.2)

THE ON/OFF TRIGGER SWITCH

This machine is equipped with a safety start trigger switch.

To start the tool:

- Push in the safety lock button on the side of the handle with your thumb.
- Depress the main trigger switch to start the motor.

WARNING: Never start the saw with the cutting edge of the saw blade in contact with the workpiece surface.

MAKING A CUT

- With the cutting head in the upper position, switch on the motor and allow it to reach full operational speed.
- Gently lower the cutting head.
- Introduce the blade into the material slowly, using light pressure at first to keep the blade from grabbing.
- Gradually increase the pressure as a blade enters the workpiece. Do not 'force' the machine. Let the saw blade do the work.

Note: Cutting performance will not improve by applying undue pressure on the machine and doing so may cause blade and motor life to be reduced.

Reduce the pressure as the blade begins to exit the material.

- On completion of a cut allow the cutting head to return to its upper position and turn off the motor.
- Only remove your hands, or the workpiece from the machine, after the motor has completely stopped and the stationary blade is covered by the lower blade guard

8) EXTENSION CABLE SELECTION

Note: Make sure the proper extension cord is used and is in good condition.

The use of any extension cord will cause loss of power. To keep this to a minimum and prevent overheating and motor burnout, use the information below to determine the minimum wire size extension cord.

EXTENSION CORDS

Use only 3-wire extension cords that have 3-prong grounding plugs and 3-pole receptacles that accept the tool's plug. When using a power tool at a considerable distance from the power source, use an extension cord heavy enough to carry the current that the tool will draw. An undersized extension cord will cause a drop-in line

voltage, resulting in a loss of power and causing the motor to overheat. Use the information provided below to determine the minimum wire size required in an extension cord. Only round jacketed cords listed by Underwriter's Laboratories approval should be used.

For 110v supply: 3.5metres of 3 core x 1.5mm²

For 230v supply: 26metres of 3 core x 1.5mm²

When working with the tool outdoors, use an extension cord that is designed for outside use. This is indicated by the letters WA on the cord's jacket.

Before using an extension cord, inspect it for loose or exposed wires and cut or worn insulation.

9) MAINTENANCE

Note: Any maintenance must be carried out with the machine switched off and disconnected from the mains/battery power supply.

Check that all safety features and guards are operating correctly on a regular basis. Only use this machine if all guards/safety features are fully operational.

All motor bearings in this machine are lubricated for life. No further lubrication is required.

Use a clean, slightly damp cloth to clean the plastic parts of the machine. Do not use solvents or similar products which could damage the plastic parts.

WARNING: Do not attempt to clean by inserting pointed objects through openings in the machine's casings etc. The machine's air vents should be cleaned using compressed dry air. Excessive sparking may indicate the presence of dirt in the motor or worn out carbon brushes.

If this is suspected have the machine serviced and the brushes replaced by a qualified technician with Rotabroach recommended brushes.

CHIP COLLECTION TRAY

The chip collection tray should be emptied at regular intervals. We recommend that for efficiency purposes the tray be emptied when it is approximately 60% full.

To check the Chip Collection Tray:

- Turn the locking lever to the horizontal position and withdraw the tray from the machine to check the contents.
 - Empty the contents of the tray into a suitable recycling bin.
 - It may be necessary to wear a dust mask when emptying the chip collection tray.
-
- Replace the chip collection tray and return the locking lever to the vertical position to secure the tray within the machine's base.

TRANSPORTATION/STORAGE

For ease and convenience, when transporting or storing the machine, the cutting head can be held in the 'down' position.

To hold the cutting head down:

- Lower the cutting head to its lowest position.
- Rotate the cutting head Locking Pin 1/4 of a turn and allow it to deploy to the 'locked down' position.

ENVIRONMENTAL PROTECTION

Waste electrical products should not be disposed of with household waste. Please recycle where facilities exist. Check with your local authority or retailer for recycling advice.

10) MACHINE BREAKDOWN

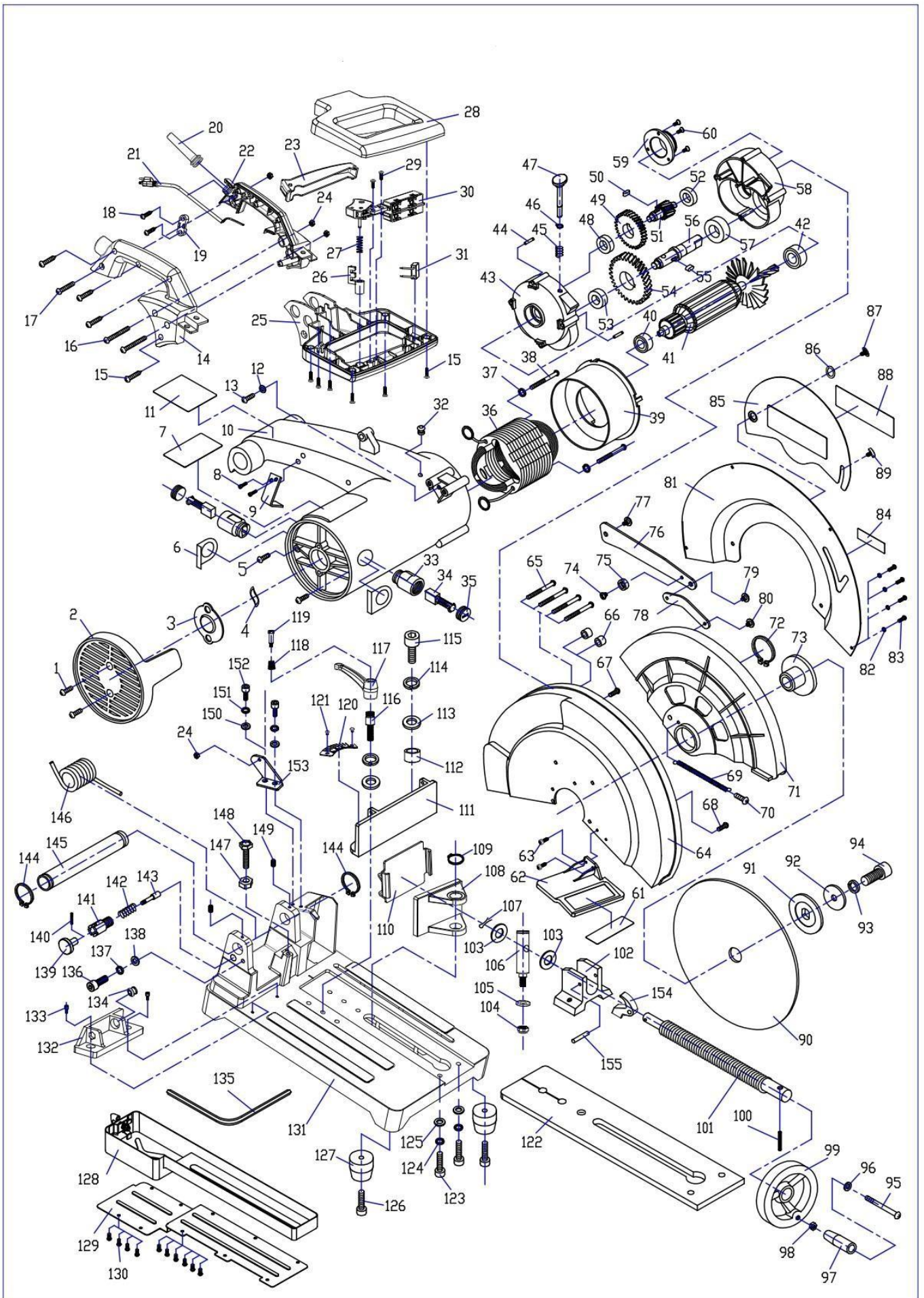

11) PARTS LIST

No.	Part No.	Description	Qty	No.	Part No.	Description	Qty	No.	Part No.	Description	Qty
1	PT0001	Screw M5x12	2	53	PT0056	Bearing 6201	1	108	PT0110	Moving Vice Jaw	1
2	PT0002	Dust Filter	1	54	PT0057	Gear II	1	109	PT0111	Circlip 22	1
3	PT0003	Bearing Support Plate	1	55	PT0058	Flat Key 6x12	1	110	PT0112	V-vice	1
4	PT0004	Washer	1	56	PT0059	Shaft(2)	1	111	PT0114	Back Vice	1
5	PT0005	Screw M5x10	2	57	PT0059	Bearing 6204	1	112	PT0115	Ring	1
6	PT0006	Contact Shield	2	58	PT0060	Gear box	1	113	PT0116	Washer 10	1
7	PT0007	Label	1	59	PT0061	Circlip	1	114	PT0117	Spring washer 10	1
8	PT0008	Cap Screw M5x15	2	60	PT0062	Screw M4x12	3	115	PT0118	Cap Screw M10x25	1
9	PT0009	Depth Stop	1	61	PT0063	Warning Lable	1	116	PT0119	Screw	1
10	PT0010	Motor Housing	1	62	PT0064	Plastic Cover	1	117	PT0120	Angle Adjust Handle	1
11	PT0011	Label	1	63	PT0065	Cap Screw M4x10	2	118	PT0121	Spring	1
12	PT0012	Washer	1	64	PT0066	Blade Housing	1	119	PT0122	Screw	1
13	PT0013	Screw M5x10	1	65	PT0067	Screw M5x90	4	120	PT0123	Angle Ruller	1
14	PT0014	Left Handle	1	66	PT0068	Rubber Ring	2	121	PT0124	Screw	2
15	PT0015	Tapping Screw ST4.2X16	10	67	PT0069	Screw M5x12	1	122	PT0125	Cast Iron Plate	1
16	PT0016	Screw M5x50	2	68	PT0070	Screw M4x10	1	123	PT0126	Cap Screw M8X40	2
17	PT0017	Screw M5x30	1	69	PT0071	Spring	1	124	PT0127	Sprign Washer 8	2
18	PT0018	Tapping Screw ST4.2X13	2	70	PT0072	Screw M4x10	1	125	PT0128	Washer 8	2
19	PT0019	Cable Clamp	1	71	PT0073	Blade Guard(2)	1	126	PT0129	Cap Screw M8X35	2
20	PT0020	Cable Sheath	1	72	PT0074	Circlip 42	1	127	PT0130	Rubber Foot	2
21	PT0021	Cable 110v	1	73	PT0075	Inner Flange	1	128	PT0131	Swarf Tray	1
	PT0022	Cable 230v	1	74	PT0076	Screw	1	129	PT0132	Swarf Tray Cover	1
22	PT0023	Right Handle	1	75	PT0077	Wheel	1	130	PT0133	Screw M4x10	10
23	PT0024	Trigger	1	76	PT0078	Connecting Rod (1)	1	131	PT0190	Base	1
24	PT0025	Nut M5	4	77	PT0079	Screw	2	132	PT0142	Wrench Holder	1
25	PT0026	Lower Handle	1	78	PT0080	Connecting Rod (2)	1	133	PT0143	Screw M5x15	2
26	PT0027	Safety Switch	1	79	PT0081	Screw	1	134	PT0144	Rubber Ring	1
27	PT0028	Spring	1	80	PT0082	Screw	1	135	PT0145	Allen Wrench 8MM	1
28	PT0029	Upper Handle	1	81	PT0083	Blade Guard(3)	1	136	PT0146	Cap Screw M8X25	1
29	PT0030	Tapping Screw ST4.2X13	2	82	PT0084	Spring Washer 4	4	137	PT0147	Spring washer 8	1
30	PT0031	Switch	1	83	PT0085	Screw M4x10	4	138	PT0148	Washer 8	1
31	PT0032	Capacitor	1	84	PT0086	Label	1	139	PT0149	Lock	1
32	PT0033	Rubber Ring	1	85	PT0087	Blade Guard Cover	1	140	PT0150	Pin 3x18	1
33	PT0034	Carbon Brush Holder	2	86	PT0088	Washer	1	141	PT0151	Lock Base	1
34	PT0035	Carbon Brush	2	87	PT0089	Screw	1	142	PT0152	Spring	1
35	PT0036	Carbon Brush Holder Cap	2	88	PT0090	Label	1	143	PT0153	Lock Pin	1
36	PT0037	Field Coil 110v	1	89	PT0091	Screw	1	144	PT0154	Circlip 24	2
	PT0038	Field Coil 230v	1	90	PT0092	Blade	1	145	PT0155	Pivot Pin	1
37	PT0039	Spring Washer M5	2	91	PT0093	Outer Flange	1	146	PT0156	Torsion spring	1
38	PT0040	Screw M5x80	2	92	PT0094	Washer	1	147	PT0157	Nut M8	1
39	PT0041	Air Buffle	1	93	PT0095	Spring Washer	1	148	PT0158	Screw M8 x 50	1
40	PT0042	Bearing 6200	1	94	PT0096	Cap Screw M10X30	1	149	PT0159	Grub screw M5	2
41	PT0043	Armature 110v	1	95	PT0097	Screw M6X63	1	150	PT0160	Washer M6	2
	PT0044	Armature 230v	1	96	PT0098	Washer	1	151	PT0161	Spring washer M6	2
42	PT0045	Bearing 6202	1	97	PT0099	Plastic Handle	1	152	PT0162	Cap screw M6 x 20	2
43	PT0046	Gearbox Cover	1	98	PT0100	Nut	1	153	PT0163	Connecting plate	1
44	PT0047	Key M5x12	2	99	PT0101	Wheel Handle	1	154	PT0164	Movable seat	1
45	PT0048	Spring	1	100	PT0102	Pin 4x25	1	155	PT0165	Pin	1
46	PT0049	Circlip	1	101	PT0103	Screw Rod	1				
47	PT0050	Spindle Lock	1	102	PT0104	Vice Screw Support	1				
48	PT0051	Bearing 6000	1	103	PT0105	Washer	1				
49	PT0052	Gear I	1	104	PT0106	Locking Nut M10	1				
50	PT0053	Flat Key 5x12	1	105	PT0107	Washer	1				
51	PT0054	Shaft	1	106	PT0108	Connecting Rod	1				
52	PT0055	Bearing 6200	1	107	PT0109	Split Pin 3x26	1				

- Applies to machines manufactured from August 2021 onwards

12) TROUBLE SHOOTING

Problem	Probable Case	Suggested Corrective Action
Motor does not start	<ol style="list-style-type: none"> 1.Fuse 2.Brushes worn 3.Other 4.Low voltage 	<ul style="list-style-type: none"> -15amp time delay fuse, or circuit breaker. -See "Maintenance" section -Check power supply for proper voltage and Correct as needed
Brush sparking when switch released.	<ol style="list-style-type: none"> 1.Normal automatic brake working properly 	<ul style="list-style-type: none"> -None
Motor stalls easily	<ol style="list-style-type: none"> 1.Low voltage 2.Excessive wheel pressure when cutting 	<ul style="list-style-type: none"> -Check power supply for proper voltage and correct as needed -Pull wheel through work at a slower pace

General

Problem	Probable Case	Suggested Corrective Action
Blade hits base or work surface	<ol style="list-style-type: none"> 1.Misalignment 2.Adjust down stop 	<ul style="list-style-type: none"> -Check alignment
Cut not square	<ol style="list-style-type: none"> 1.Defective wheel 2.Work not positioned properly 3.Excessive wheel pressure 	<ul style="list-style-type: none"> -Replace immediately -Position work properly -Lessen wheel pressure
Power head won't fully rise or blade guard won't fully close	<ol style="list-style-type: none"> 1.Lubrication needed 2.Part failure 3.Pivot spring or guard spring not replaced properly after service 4.Dirt sticking to stops 	<ul style="list-style-type: none"> -See "Lubrication" section -Inspect/clean stops
Blade binds, jams, burns workpiece. Rough cuts	<ol style="list-style-type: none"> 1.Improper operation 2.Dull blade 3.Improper blade 	<ul style="list-style-type: none"> -See "Operation" section -Replace or sharpen wheel -Replace with 14" diameter wheel designed for the material being cut
Tool vibrates or shakes	<ol style="list-style-type: none"> 1.Sawblade not round 2.Sawblade damaged 3.Sawblade loose 4.Other 	<ul style="list-style-type: none"> -Replace wheel -Replace wheel -Tighten arbor screw

RotabroachTM

13) WARRANTY STATEMENT

RotabroachTM warrants its machines to be free from faulty materials, under normal usage of machines, for a period of 12 months from initial date of purchase. All other parts (excluding cutters) are under warranty for 90 days, provided that the warranty registration card (or online registration) has been completed and returned to RotabroachTM or its designated distributor within a period of (30) days from the purchase date. Failure to do so will void the warranty. If the stated is adhered to RotabroachTM will repair or replace (at its option) without charge any faulty items returned.

This Warranty does not cover:

1. Components that are subject to natural wear and tear caused by the use not in accordance with the operators' instructions
2. Defects in the tool caused by non-compliance with the operating instructions, improper use, abnormal environment conditions, inappropriate operating conditions overload or insufficient servicing or maintenance.
3. Defects caused by using accessories, components or spare parts other than original RotabroachTM parts.
4. Tools to which changes or additions have been made.
5. Electrical components are subject to manufacturer's warranty.

Your online registration can be submitted at www.rotabroach.co.uk

The warranty claim must be logged within the warranty period. This requires the submission or sending of the **complete** tool in question with the original sales receipt which must indicate the purchase date of the product. A complaint form must also be submitted prior to the return.

This can be found online at www.rotabroach.co.uk. Failure to complete this form will result in the delay of your claim.

All goods returned defective must be returned pre-paid to RotabroachTM, in no event shall Rotabroach[®] be liable for subsequent direct, or indirect loss or damage.

THIS WARRANTY IS IN LIEU OF ANY OTHER WARRANTY, (EXPRESSED OR IMPLIED) INCLUDING ANY WARRANTY OF MERCHANTABILITY OR FITNESS FOR A PARTICULAR PURPOSE. ROTABROACHTM RESERVE THE RIGHT TO MAKE IMPROVEMENTS AND MODIFICATIONS TO DESIGN WITHOUT PRIOR NOTICE

Known and Trusted Worldwide for Quality, Performance and Reliability